

Eletta Flow Meter

Manual

Installation and Operation



M-series

About this manual

- This manual relates to the M-series Flow Meter.
- Note that the latest version of this manual is always available as a PDF file on our web site www.eletta.com.
- On our site you also find other interesting information such as leaflets, newsletters and application reports.

Proprietary Rights

This manual contains confidential technical data, including trade secrets and proprietary information, that are the property of Eletta Flow AB, Sweden.

Any changes or alterations to downloaded or printed Eletta original documentation such as manuals, drawings, leaflets, newsletters etc, are not permitted without a written permission from Eletta Flow AB, Sweden.

These data are only disclosed to you under permission of limited use within your company. Use for manufacturing or processing is not permitted.

Any other use of data and information is strictly prohibited without prior written permission from Eletta Flow AB, Sweden.

Safety instructions

Warning!



In this manual, this warning symbol is used to emphasize where you have to be particularly careful to avoid injury or product damage.

- The M-series Flow Meter must not be installed in explosive environments. The product is presently not Ex-hazardous approved (pending).
- To prevent injury when installing the Flow Meter, make sure that the system is not pressurized from gas or liquid flow.
- There are no user serviceable parts inside the instrument. Eletta takes no responsibility for injury or damage caused by unauthorized dismounting.
- Never open the instrument by unscrewing the four hexagon bolts at the top while the instrument is pressurized.
- The electrical installation must only be made by authorized personnel.
- Disconnect all power connections before installation or service.
- Never exceed the maximum static pressure, which is specified on the product label, and in this manual.
- The product is ESD (Electro-Static Discharge) sensitive. Make sure that correct grounding is used.
- Make sure that the correct electrical power is used.

Customer Service

Customer Service Center

Our Customer Service Center will answer any of your commercial or technical questions during normal office hours* 8.00 - 16.30 C.E.T., (8 am - 4.30 pm Central European Time).

Our switchboard is manned 7.00 – 19.00 C.E.T. During non-office hours Monday- Friday you can always leave a message at the switchboard, and our Customer Service staff will contact you as soon as possible.

Questions or inquires will be responded to immediately, either by phone, fax or e-mail.

*The normal office hours are not valid during National Holidays and annual plant close down, such as Christmas and summer holidays.

About Troubleshooting

We have tried to make this manual as clear and comprehensive as possible, but naturally we understand that you might run into problems that are not described in this manual.

If this would happen, we kindly ask you to first check the manual once again before contacting our Distributors or Eletta Flow AB in Sweden. This is to save valuable time for any of us involved in Eletta products.

If you after this check still are not able to solve your problem, our Customer Service staff is more than happy to help you.

We also refer to the trouble-shooting section 6.2 that answers frequent questions.

Contact

Phone + 46 8 603 07 70 Switchboard
 + 46 8 603 07 80 Orders and Inquires

Fax + 46 8 646 10 40

Postal Mail Eletta Flow AB
 P.O. Box 5084
 SE-141 05 Huddinge
 SWEDEN

E-mail info@eletta.com

Web www.eletta.com

Distributors

Eletta has appointed a number of distributors all over the world. You will find more information about your closest distributor at our web site www.eletta.com, or by contacting our Customer Service Center.

Contents

About this manual.....	2
Proprietary Rights.....	2
Safety instructions.....	3
Warning!.....	3
Customer Service	4
Customer Service Center	4
About Troubleshooting	4
Contact	4
Distributors	4
Contents	5
1 General Information	6
1.1 General Description	6
1.2 The Differential Pressure Principle	6
1.3 Accuracy	6
1.4 Overview.....	6
1.5 Pipe Dimensions.....	8
1.6 ISO Certification.....	8
1.7 PED Certification	8
1.8 EMC.....	8
2 Installation	9
2.1 Unpacking.....	9
2.2 Preparations	10
2.3 Installing the Flow Meter.....	12
2.4 Separate Mounting	16
2.5 Electrical Installation	21
3 Differential Pressure Measurements	22
3.1 The Differential Pressure Principle	22
3.2 Pressure Drop.....	23
3.3 The Output Signal.....	25
4 Installation Modifications	26
4.1 Change of Flow Direction	26
4.2 Change of Flow Range.....	26
4.3 Alarm levels	27
5 Maintenance	28
5.1 Housing.....	28
5.2 Electrical wiring and connections	28
5.3 Bolts and screws.....	28
5.4 Process connection	28
5.5 Pipe Section.....	28
6 Trouble Shooting	29
6.1 Reference flow.....	29
6.2 FAQ (Frequently Asked Questions).....	29
6.3 Electrical connections	30
6.4 Spare parts	30
7 Technical Specification	31
7.1 Measurement flow ranges (liquids).....	34
7.2 Type plates	35
8 Exploded diagram	36

1 General Information

1.1 General Description

The M-series Eletta Flow Meters are used to measure and control flows of liquids and gases in pipes with sizes 15-25 mm. For larger sizes it is possible to use the M-model Control Unit together with the classic Pipe Units (GL, FA, GSS, FSS). Please contact Eletta for more information.

Note that the M-series Flow Meters comes factory calibrated and programmed at delivery. When ordering, data for the specific application are collected and programmed into the processor of the instrument. This enables quick and easy installation by the user. Only mechanical mounting and electrical connection are needed. No further adjustments have to be done by the user.

However, it is possible to adjust most parameters in field after installation using the Eletta M-WIN Software Kit. You find more information about this in the M-WIN Software Manual.

1.2 The Differential Pressure Principle

The M-series Eletta Flow Meters are based on the proven and dependable *differential pressure principle*, and use interchangeable orifice plates for different pipe dimensions and measuring ranges. See section 3 for more information about the measurement principle.

The M-series Flow Meter is factory calibrated for the differential pressure range 0-500 mbar. Alternative ranges can be set in-field using our M-WIN software, or determined at the time of ordering.

1.3 Accuracy

The M-series Flow Meter measures media pressure using two independent pressure transducers. The measurement values are then converted to a flow value by the microprocessor. The M-series Flow Meter has an accuracy of +/- 1% F.S.(Full Scale) of the measured differential pressure.

1.4 Overview

The instrument mainly consists of two parts, the *Pipe Section* and the *Control Unit*.

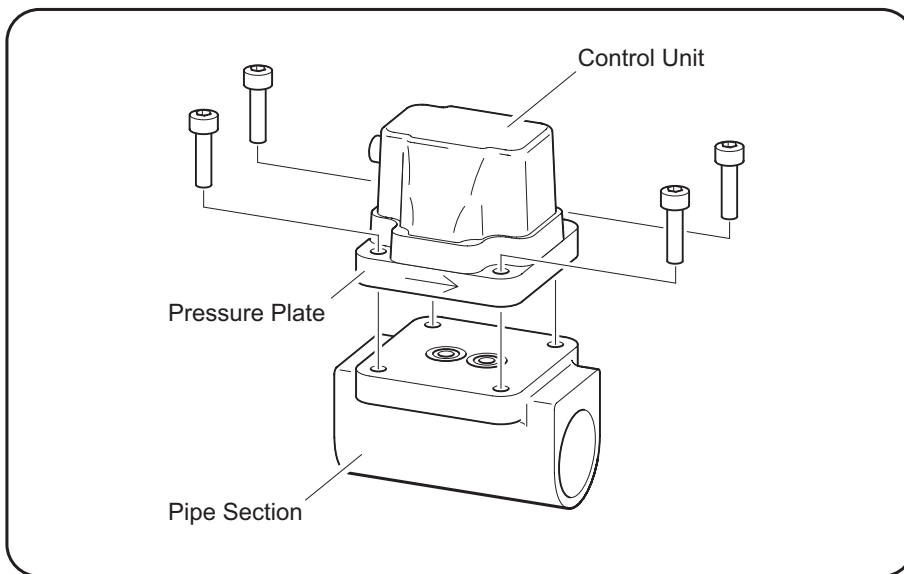

603A2E5

The Pipe Section is mounted in-line in the process pipe, and the Control Unit is normally mounted onto the Pipe Section. In some applications, for example when measuring hot media, the Control Unit may be installed remotely from the Pipe Section. See section 2.4.

The Pipe Section contains the exchangeable Orifice Plate and the Plate Holder.

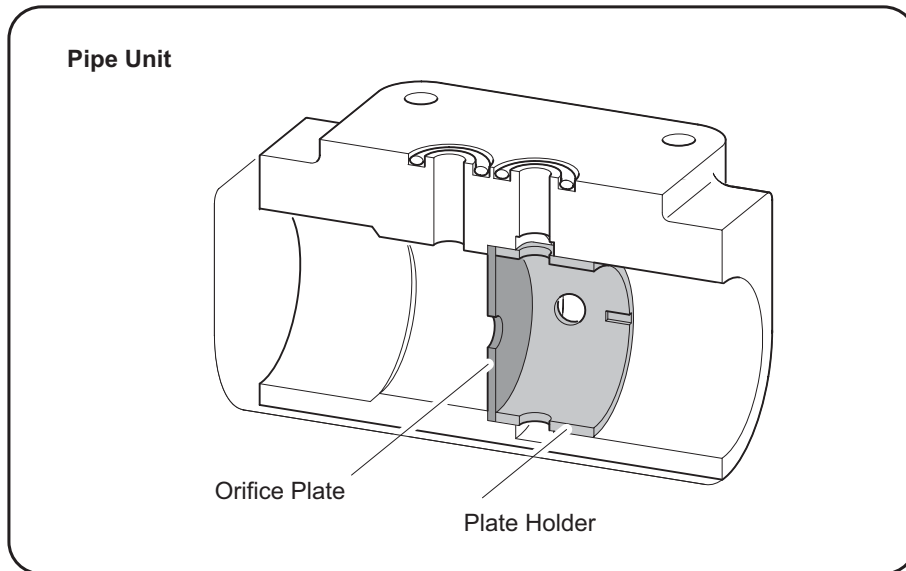

The Control Unit contains the two pressure sensors, the circuit board and the electrical connector. The circuit board outputs 4-20 mA and flow alarm through the output connector.

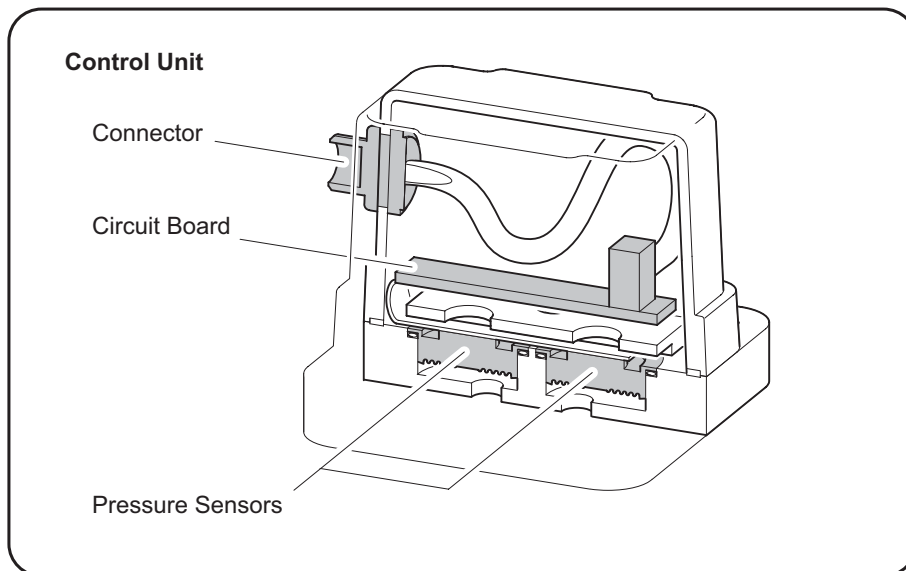

In order to get the instrument to work properly with high accuracy, it is very important that the instrument is installed correctly according to the installation instruction, see chapter 2.

1.5 Pipe Dimensions

The Pipe Section is available in various dimensions and materials according to the following table.

Threaded (G)		
Pipe Material	Type	Available Dimensions*
Copper Alloy	M-G15BR	DN 15 (1/2" BSPP)
	M-G20BR	DN20 (3/4" BSPP)
	M-G25BR	DN25 (1"BSPP)
Stainless Steel	M-G15SS	DN 15 (1/2" BSPP)
	M-G20SS	DN20 (3/4" BSPP)
	M-G25SS	DN25 (1"BSPP)

* Use NPT adapters for NPT connection (adapters are not included).

1.6 ISO Certification

Eletta Flow AB in Sweden is certified according to ISO 9001 since 1996, and ISO 14000 since 2002.

1.7 PED Certification

Eletta Flow AB is PED certified (Pressure Equipment Directive).

1.8 EMC

Eletta Flow Meters conforms with the following EU directives for electromagnetic compatibility: 89/336/EEC (EN 61 000 - 6-2:2001-1 and EN 61 000 - 6-3:2001).

2 Installation

2.1 Unpacking

Before installation, we kindly ask you to perform the following steps:

- 1) Check that there are no external damages to the delivery box.

If there are damages, check if the Flow Meter has been damaged. If it is damaged, contact your forwarder/shipper to claim replacement, or cost of replacement.

- 2) Check what has been delivered corresponds to the Packing list.
- 3) Also check the identification tag of the Flow Meter against your purchase order to make sure that the correct product has been delivered.

All Flow Meters are individually packed to prevent dust to get into the Pipe Section, since this could cause malfunction. Note that the connection cable is also found in the box.

The box is made out of recycled environmental friendly material, and we kindly ask you to deal with the material in a way that will have as little impact on the environment as possible.

2.2 Preparations

2.2.1 Preparations for normal installation

Before installation, we kindly ask you to perform the following steps:

- 1) Eletta recommends that you choose a correct position for the flow meter in your pipe system. The following table serves as a guideline.

Process Media	Correct installation position
Liquid	Low level
Gas	High level

- 2) Check that your desired flow direction corresponds to the direction of the Flow Meter, which is indicated by an engraved arrow on the Pressure Plate. Note that the cable connector shall always be located on the upstream side. See section 4.1 for information about how to change the flow direction.

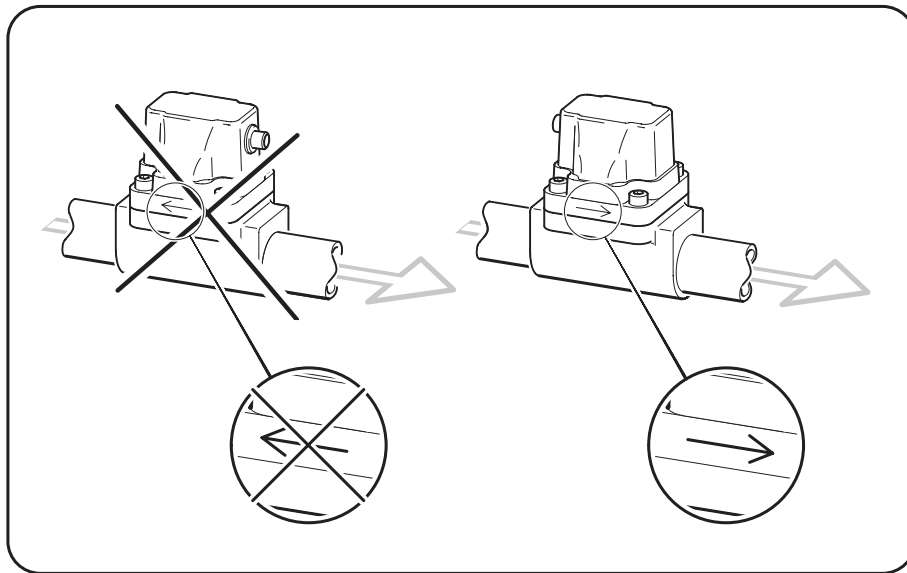

- 3) Check that the Pipe Section has the correct threads to match your piping threads.
- 4) Make sure that you use correct pipings corresponding to the diameters specified in section 2.3 5).

2.2.2 Preparations for Separate Mounting

Read this section if you plan to install the Control Unit remotely from the Pipe Section.

See section 2.4 for more information about Separate Mounting (i.e. remote installation of the Control Unit).

Perform steps 1) – 4) according to the previous section 2.2.1 (normal installation).

5) Check that the plastic hoses are not damaged.



The plastic hoses shall not be used for temperatures higher than 90 °C (194 °F) or pressures higher than 10 bar (145 PSI). If your process temperature or pressure exceeds these levels, we recommend you to use copper or stainless steel tubing. Choose material with respect to the type of liquid or gas in your system.

2.3 Installing the Flow Meter



- *Disconnect all electrical power before installation!*
- *Make sure that the system is not pressurized!*

- 1) Mount the Flow Meter in any desired direction, vertical or horizontal.

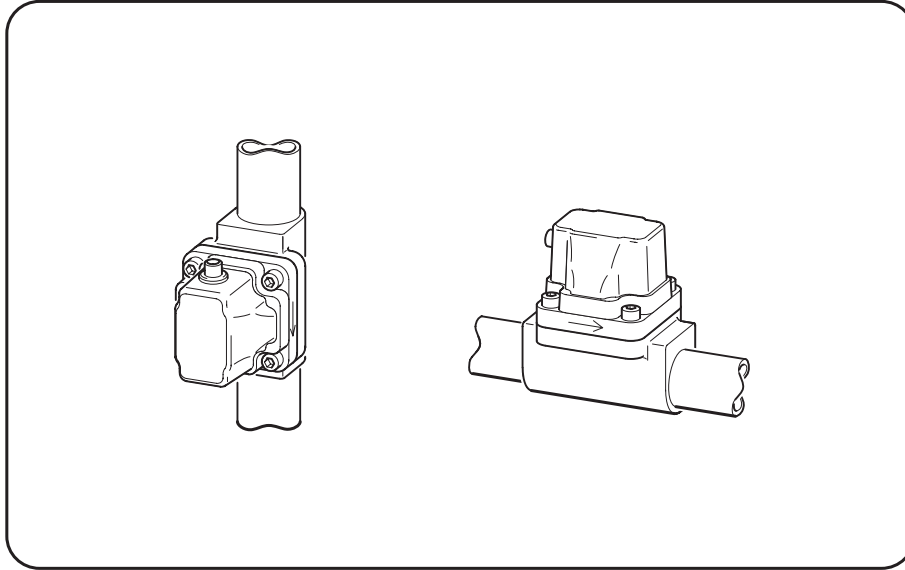

606A2E5

- 2) If you mount the Flow Meter horizontally, make sure that the Control Unit always is mounted upwards, i.e. on top of the Pipe Section, and not on the underside. The reason for this is to prevent particles in a fluid to collect in the pressure sensor chambers. Please use a filter in the pipeline if your system fluid contains particles.

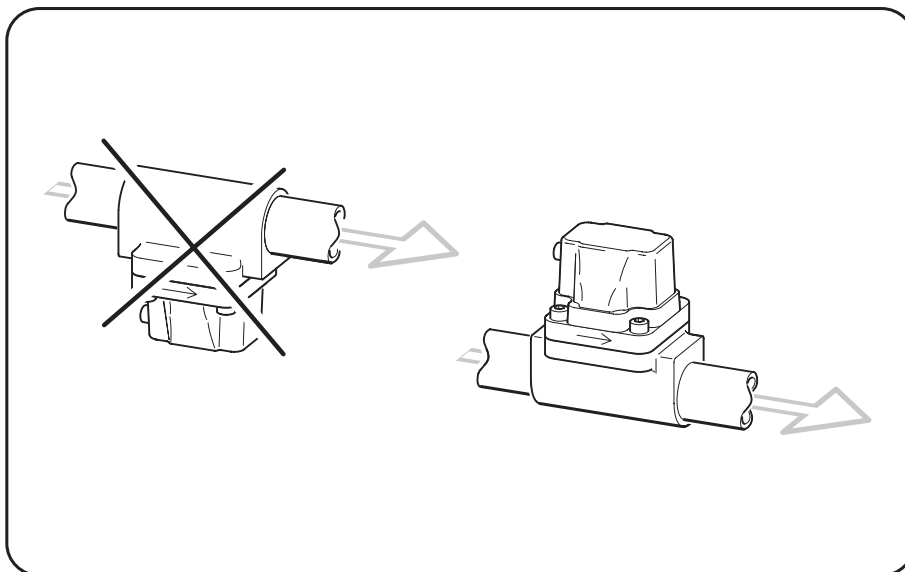

609A2E5

- 3) Make sure that you mount the Flow Meter according to the correct flow direction, which is indicated by an engraved arrow. Note that the cable connector shall always be located on the upstream side.

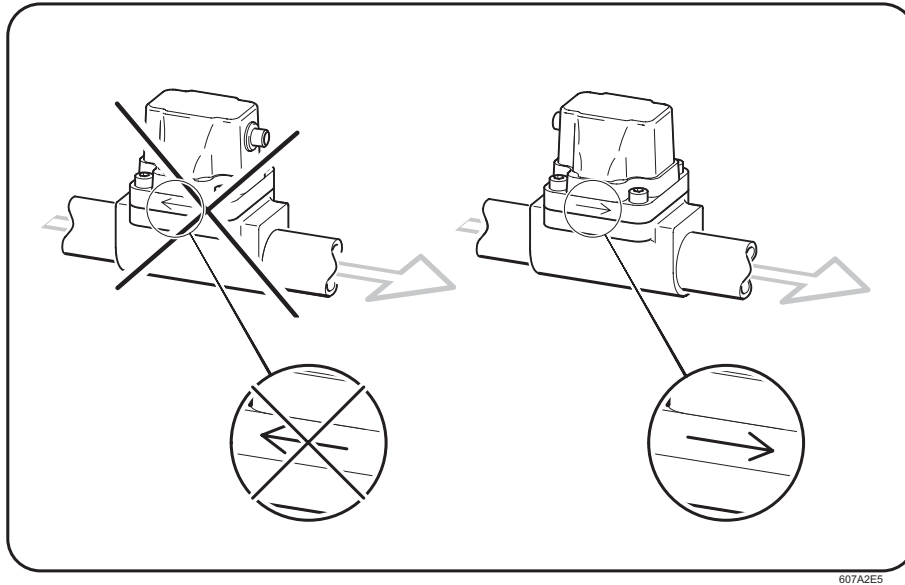

- 4) Make sure that the installation location of the Flow Meter is rigid and vibrationfree. If necessary, use the two threaded M6 holes on the rear side of the pipe section to mount the flow meter on a wall or similar using an angle bracket.

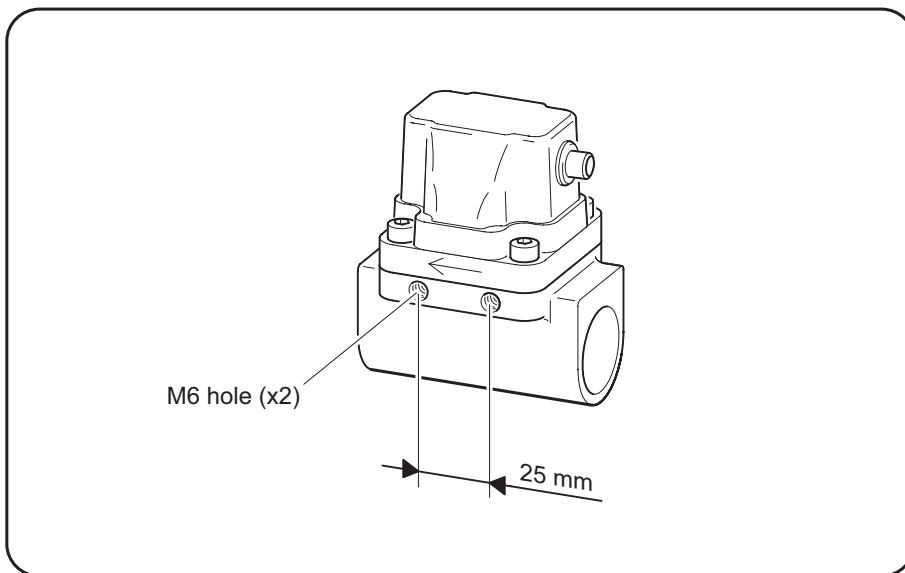

If your system still suffers from extensive vibrations, we recommend separate mounting of the Pipe Section and Control Unit. See section 2.4

- 5) Make sure that you use the correct piping. The available threaded Pipe Sections have *inside diameters* according to the following table.

Type	Pipe dimension	Inside diameter
M-G15BR M-G15SS	DN 15	16 mm
M-G20BR M-G20SS	DN 20	21 mm
M-G25BR M-G25SS	DN 25	26 mm

If the inner diameter of your piping, including fittings, does not correspond to the table above, inaccuracy may occur.

The reason is that such fittings, with an inside diameter that is too small, will create a media jet stream, which results in that the differential pressure gets too low, thereby causing inaccurate measurement results.

If you still have to use a tube fitting having an inside diameter that is too small, make sure you place it outside the straight runs described in the next step (6).

- 6) To obtain maximum accuracy, make sure that the system pipe has a sufficiently long straight run before the Flow Meter (upstream). We recommend that the run corresponds to at least 15 times the present pipe diameter.

Also make sure that the run after the Flow Meter (downstream) is at least 5 times the diameter.

Also make sure that there are no valves, bends or diameter changes. This is to avoid disturbances that may cause inaccuracy.

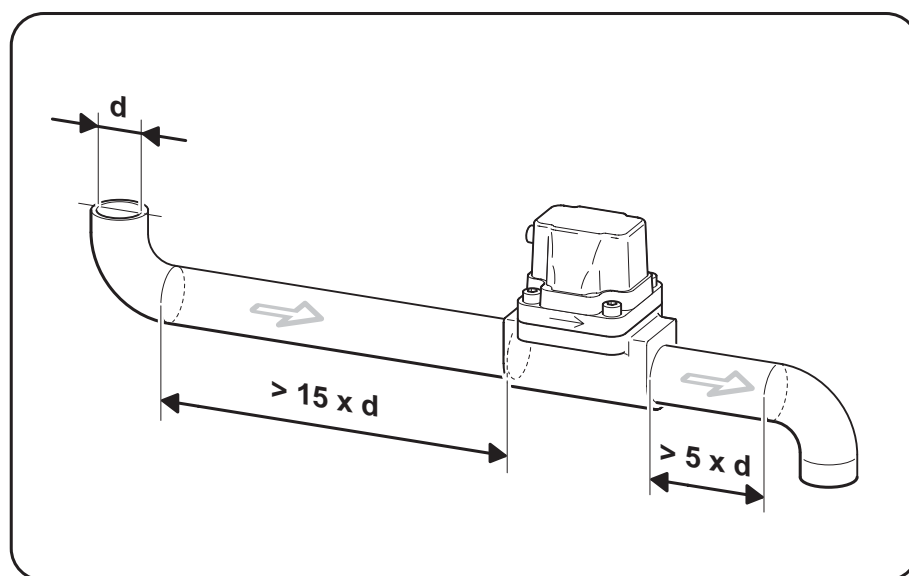

608A2E5

Note

In applications where maximum accuracy is not necessary, the lengths of the runs can be reduced. Note that it is practically impossible to predict where and when a flow gets stable after a disturbance. Therefore, the recommendation above serves only as a guideline, i.e. a method that has proven to secure the measurement accuracy. If shorter runs are used, Eletta neither can guarantee the specified maximum accuracy, nor predict the flow in your specific application.

2.4 Separate Mounting

Sometimes, the pipe Section and the Control Unit need to be mounted at different locations. Reasons could be lack of space, high system media temperature, or vibrations. The following sections explains Separate Mounting. Go directly to 2.4.1 if you are looking for installation instructions.

Overview

The orifice plate creates two pressures, one on each side of the plate. These pressures are distributed to the two pressure sensors in the Control Unit via short channels. When mounting the Pipe Section and the Control Unit separately, these channels are extended by using two plastic hoses. The hoses are mounted between the Pipe section and the Control Unit using two adapters.

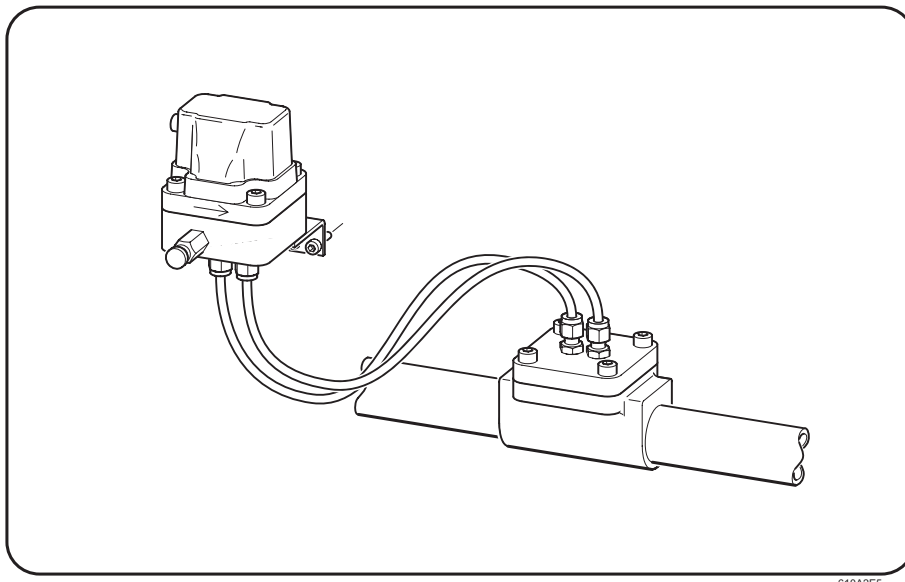

610A2E5

Hoses

As a standard, two 1,75 m (5.74 feet) PA plastic hoses come with the instrument. The diameter is 6 mm (0,23 inch) and suited for a maximum temperature of 90 °C (194 °F) and a pressure of 10 bar (145 PSI).



The plastic hoses shall not be used for temperatures higher than 90 °C (194 °F) or pressures higher than 10 bar (145 PSI). If your process temperature or pressure exceeds these levels, we recommend you to use copper or stainless steel tubing. Choose material with respect to the type of liquid or gas in your system. Such tubes are not included in the product.

Adapters

In order to perform a separate mounting, you need two adapters that are mounted on the Pipe Section and the Control Unit. The adapters are optional, they do not come with the instrument as a standard.

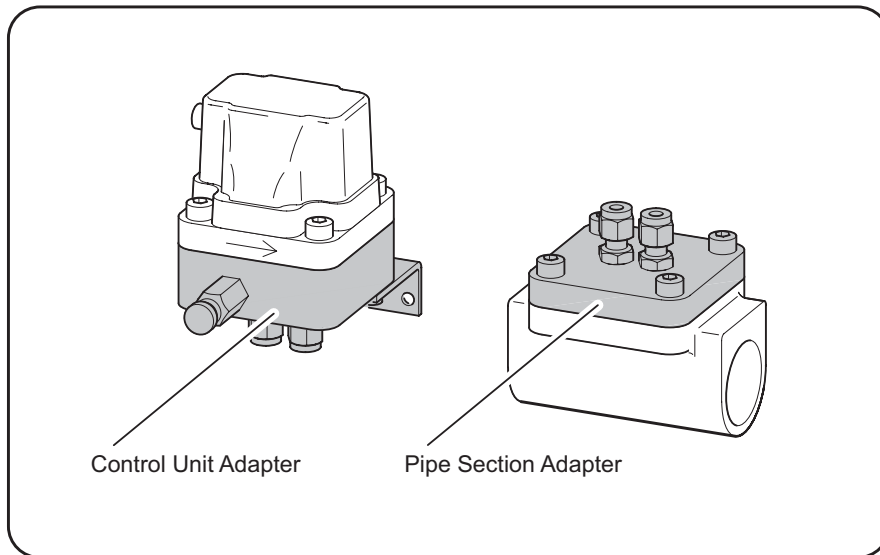

The Control Unit Adapter has valves for discharging entrapped air. There is also a mounting bracket for wall mounting..

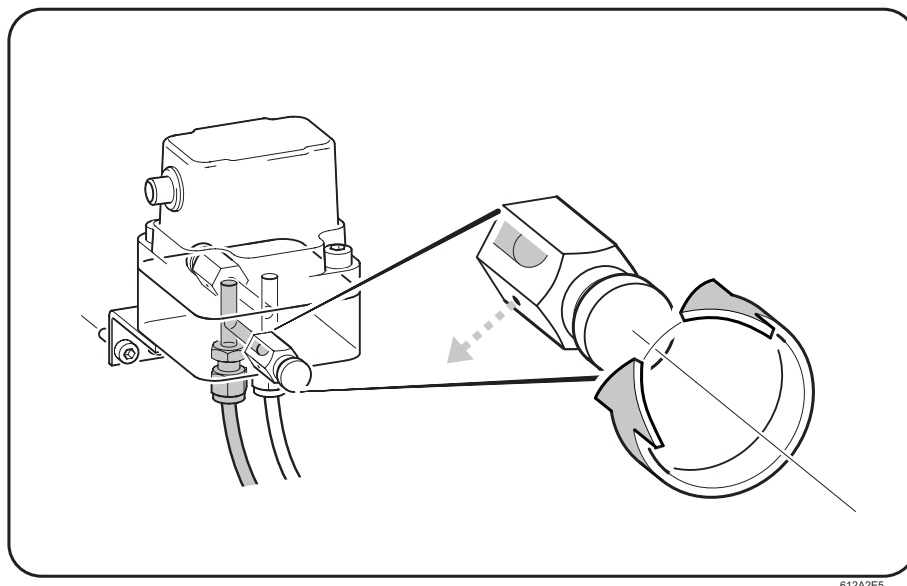

Distance between the units

We recommend mounting the Pipe Section and the Control Unit as close to each other that is practically possible, as this will facilitate future trouble-shooting and on-site calibration.

Chemical reactive media

The plastic hoses can be replaced by 6 mm metal tubes (for instance copper or stainless steel) depending on the system media, pressure and temperature. Such tubes are not included in the product. If you are measuring chemical reactive media, check with your supplier which is the most suitable material to use for the tubing.

2.4.1 Separate Mounting - Installation

- 1) Install the Pipe Section according to the instruction in chapter 2.3. In this case you can mount the Pipe Section in any direction, vertically or horizontally, and with the pressure channels pointing upwards, downwards or to the side.
- 2) Mount the Pipe Section Adapter to the Pipe Section.

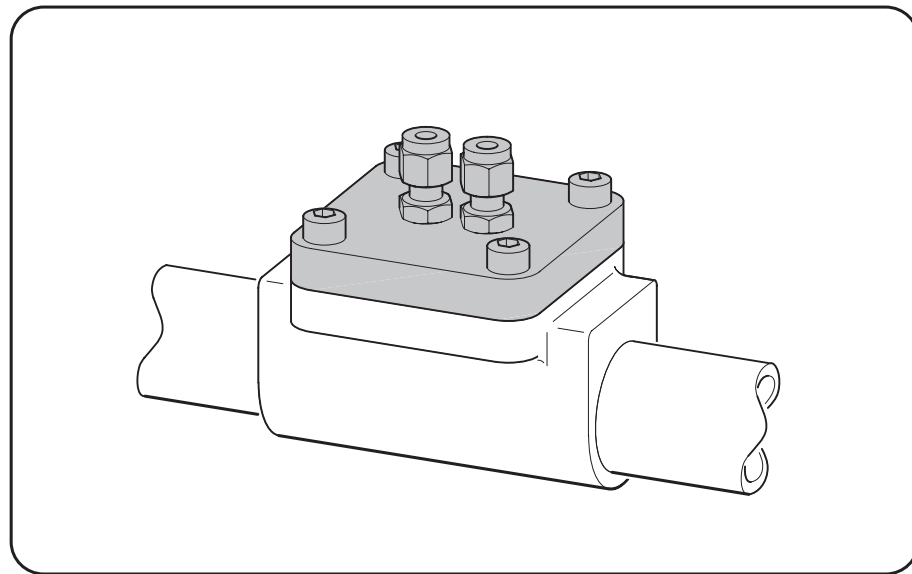

613A2E5

- 3) Find a suitable place for mounting the Control Unit. We recommend that the Control Unit is easily accessed with respect to maintenance. Also consider future mounting of pipes or other equipment, which could prevent access to the Control Unit.
- 4) Mount the Control Unit Adapter to the Control Unit.

- 5) Mount the Control Unit Adapter to a wall, a pipe or other rigid object. Use the optional bracket.

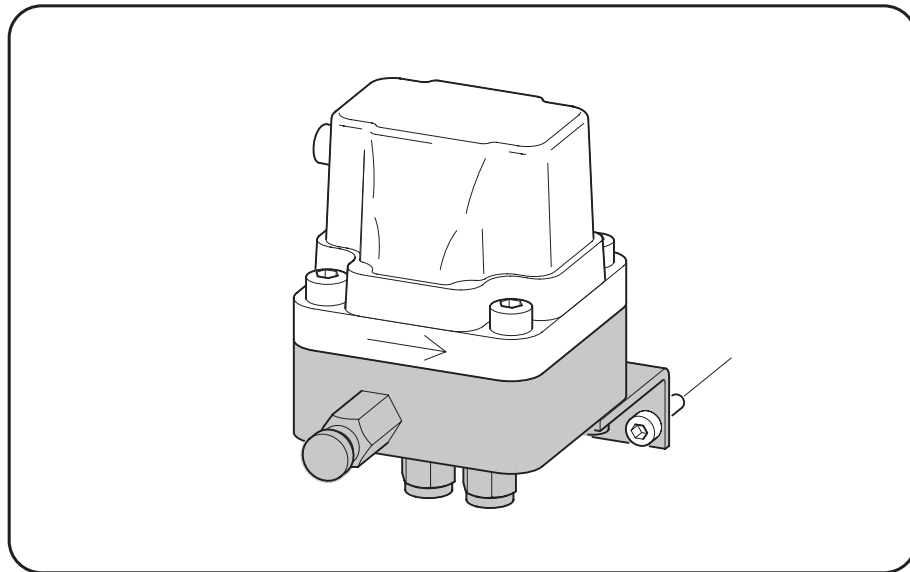

614A2E5

- 6) Make sure that the hoses (or tubes) are not too short.
- 7) Make sure that the hoses have the same length. The reason is to avoid uneven pressures in the two channels, which will cause inaccuracy.
- 8) The both adapters have engraved “+” and “-” signs. Connect one of the hoses between the respective “+” signs. The “+” sign represents the upstream side. Tighten with care.

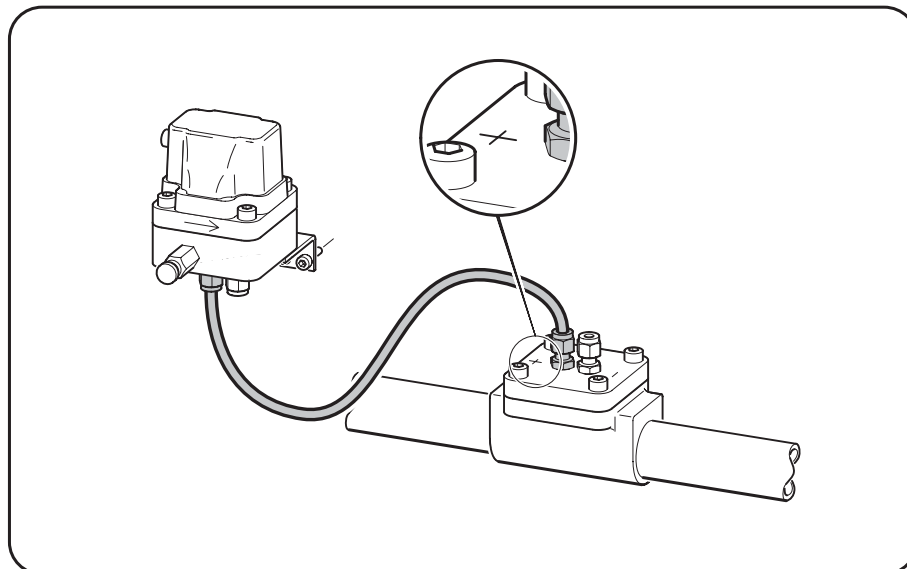

615A2E5

- 9) Connect the other hose between the respective “-“ signs. The “-“ sign represents the downstream side. Tighten with care.

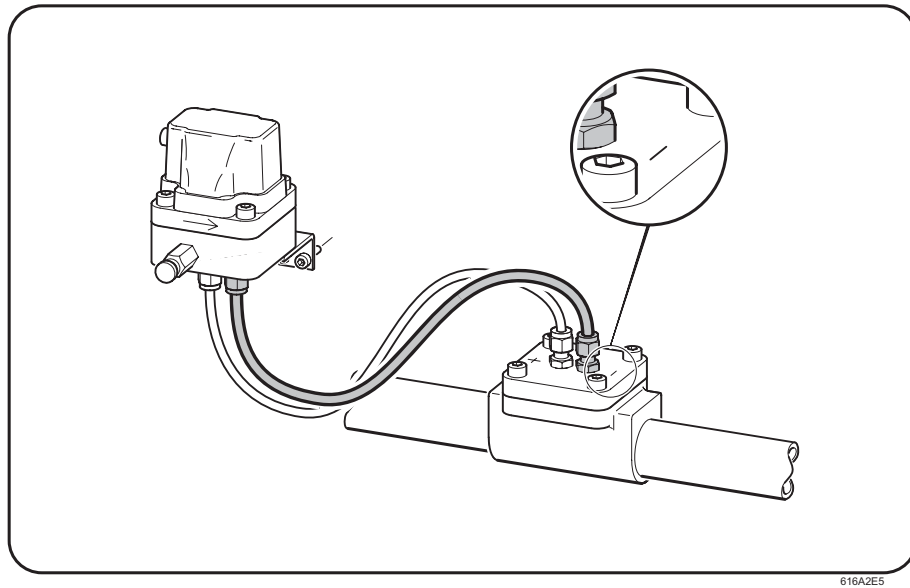

Note

The first time the system is filled up with liquid, please make sure to remove all entrapped air in the hoses. Air is a compressible media which may cause inaccurate measurement results.

2.4.2 Valve mounting

Mounting valves on the hoses or tubes will help you to easily remove or exchange the Control Unit at full system pressure.

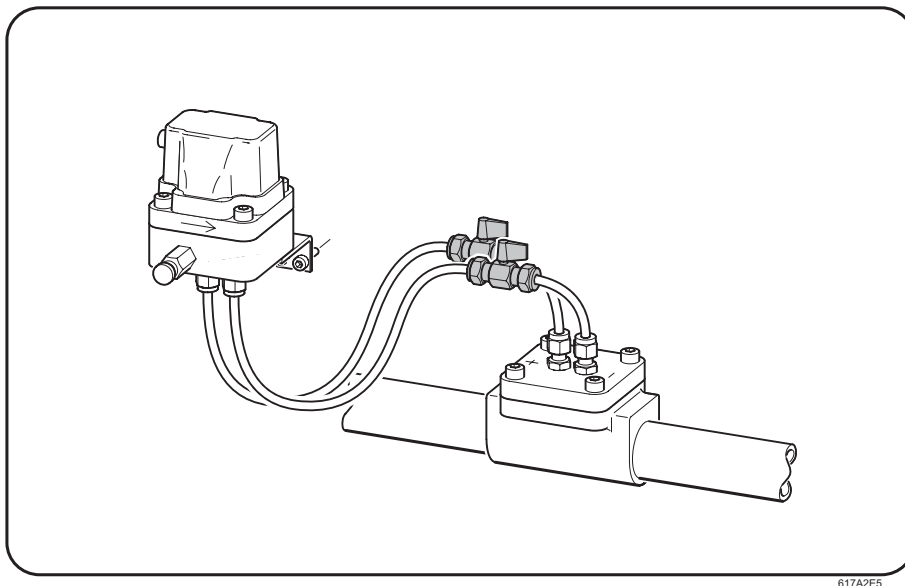

Valves are not included in the product.

2.5 Electrical Installation



The electrical installation must only be made by authorized personnel!



Do not install the M-series flow meter in Ex-hazardous areas!

2.5.1 Connections

The connection cable is found in the delivery box together with the flow meter. The cable is 2,5 m having a circular connector with screw locking.

If you want to extend the cable which comes with the flow meter, then use a three lead cable for the output signals, each lead having a conductive area of at least 0,25 mm² (0,00039 inch²).

The following table describes how the leads of the delivered connection cable are used.

Lead colour	Connection	Additional information
Brown	Power supply (+)	+8 to +28 VDC
Green	Alarm (+)	Outputs +8 to +28 VDC in alarm ON mode. Outputs 0 VDC in alarm OFF mode*.
White	Negative (-)	Used as negative pole for both Power Supply and Alarm

* In OFF mode, a bias voltage of approximately 0,1 – 0,5 VDC may occur due to transistor properties.

2.5.2 How to connect

Connect the connection cable like this:

- 1) Turn the cable connector to the right position.
- 2) Push the cable connector against the connector of the control unit.
- 3) Lock it by screwing the locking ring.

2.5.3 Power supply

Make sure that you use the correct power supply voltage, the allowed range is +8 to +28 VDC.

2.5.4 Alarm

If you want to use the alarm feature, connect the green alarm lead to an external relay or similar. As specified in section 2.5.1 above, the voltage in ON mode is +8 to +28 VDC.

Note

It is important that the negative pole of the relay is connected *outside* the current meter as shown in the schematic picture below.

Wiring diagram

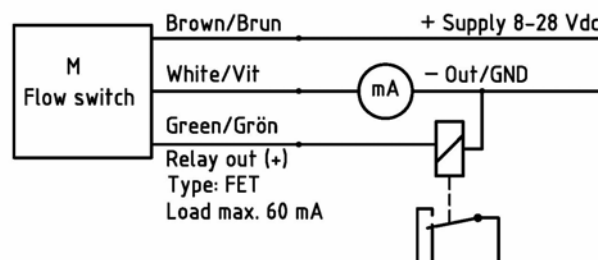

3 Differential Pressure Measurements

3.1 The Differential Pressure Principle

The function of the Eletta Flow Meters and Flow Monitors is based on the proven and dependable *differential pressure principle*. The instruments use interchangeable sharp-edged orifice plates designed for different measurement ranges.

This is probably one of the oldest and most widely used principles for flow measurements. The principle benefits from simplicity and low cost. In addition, there exist a large amount of research data and experience, which is useful when predicting the behavior of a certain orifice plate.

Inserted into the Pipe Section of the Flow Meter, the orifice plate constitutes an area restriction that causes a pressure drop after the orifice plate. This pressure drop varies with the flow rate.

This means that, in the flow direction, we will have one pressure before the orifice plate, and another after the plate. The first pressure will be slightly higher than the second.

The two pressures are led through two separate channels to separate pressure sensors in the Control Unit. The two pressures are measured and the difference is calculated. This is called the *differential pressure*.

Now, what is really interesting, the flow (Q) and the differential pressure (ΔP) turn out to be dependant of each other! The dependence can be approximated by the following formula.

$$Q = \sqrt{\Delta P}$$

The Control Unit then transforms the flow value to an analogue current output signal, which is linear to the flow.

3.2 Pressure Drop

Since the Eletta Flow Meter is based on the Differential Pressure Principle, it is inevitable that a small system pressure drop is caused. The reason is that the orifice plate reduces the flow area inside the pipe, and this will effect the pressure.

In our discussion, it is important to fully understand the two types of pressure drops. The first is the *actual pressure drop* created between the both sides of the orifice plate. The second is the *permanent pressure drop* that will slightly effect the system.

The actual pressure drop is a temporary state that we have over the orifice plate. On the downstream side of the Flow Meter the pressure will try go get back to the same conditions as on the upstream side. Normally, the flow profile will be recovered on the downstream side after approximately 10-15 times the inner diameter of the pipe.

However, due to friction losses caused by the orifice plate, that transforms transitional energy in the flow into small amounts of heat energy, the system pressure will be somewhat less on the downstream side. The size of this loss, the permanent pressure drop loss, can be calculated using two mathematical formulas.

The permanent pressure drop and the actual pressure drop are related according to the formula

$$\Delta p_P = \Delta p_a (1 - \beta^2)$$

where

Δp_P = permanent pressure loss

Δp_a = actual pressure loss

$\beta = d/D$

where

d = the diameter of the bore in the orifice plate

(contact your distributor for information about the size of the bore)

D = the inside diameter of the pipe

Normally β is in the interval 0.2 – 0.7 resulting in a permanent pressure loss of $0.96 \Delta p_a - 0.51 \Delta p_a$.

The second formula approximates the relation between the actual pressure drop and the flow:

$$\Delta p_a = (Q/Q_{max})^2 * \Delta p_{MAX}$$

where

Δp_a = actual pressure loss in mbar

Δp_{MAX} = maximum allowed differential pressure, see “Flow conditions” on the type plate.

Q = actual flow

Q_{max} = maximum flow for the orifice plate, see “Flow conditions” on the type plate .

Example

Let us assume

Q range: 0-10 l/min

Q = 5 l/min

d = 5,9 mm

D= 16.00 mm

Media pressure = 5 bar

$\Delta p_{MAX} = 500$ mbar

This gives a β of $5,9/16.00 = 0,36875$, which results in $(1-\beta^2) = 0,864$

Hence, $\Delta p_P = \Delta p_a * 0,864$

A flow of 5 l/min results in a actual pressure drop of $(5/10)^2 * 500 = 125$ mbar.

The curve below approximately shows the relation between the actual pressure loss and the flow percentage.

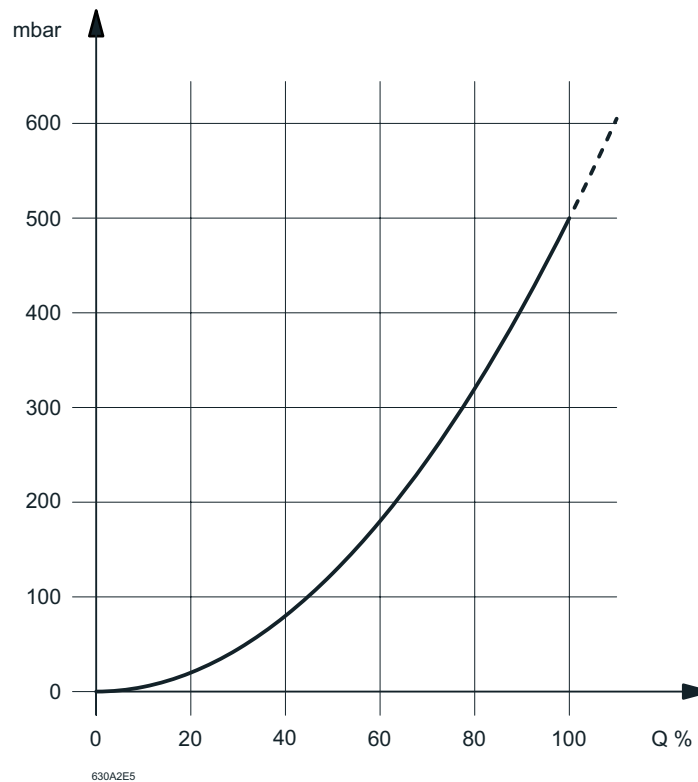

The permanent pressure drop will then be $0,864 * 125 = 108$ **mbar**

If we now compare this drop with the system media pressure of 5 bar, we find that the efficiency η is almost 98%.

$$\eta = (5 - 0,108)/5 = 97,8\%$$

This means that mounting a Flow Meter with a bore, that temporarily decreases the flow area with as much as 86%, only decreases the static pressure with approximately 2 % at 50% flow.

(End of example)

3.3 The Output Signal

3.3.1 Turn down

Each orifice plate is designed and optimized for a specific flow range and fluid. This means that there is a maximum flow value for a specific orifice plate. This value is represented by the flow percentage 100%. A flow value higher than the maximum flow value will not be measured with the same accuracy.

The analogue output signal from the Control Unit is always in the range 4-20 mA as default. This means that the maximum flow (100%), for a specific orifice plate, corresponds to the output level 20 mA.

However, the minimum flow 0% is merely theoretical since it is not possible to use the differential pressure principle if there is no flow at all. There has to be a certain minimum flow to create the different pressures on the upstream and downstream side of the orifice plate.

This minimum flow therefore will correspond to a flow percentage higher than 0%. Therefore, the Flow Meter is said to have a turn down of 1:10. In this very case, the lowest flow must be 10% of the maximum flow in order for the Flow Meter to be able to work properly.

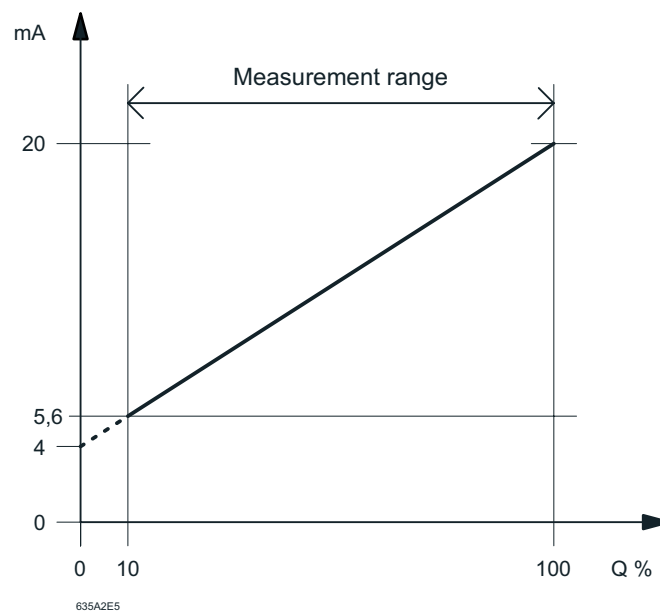

For more information about the behaviour of the output signal, we refer to the M-WIN software manual.

3.3.2 Customized range

Using our M-WIN software (option), it is possible to let the output signal range limits correspond to other values than 0% and 100 % flow.

In this way, if your application always has a flow of 40-60%, you can “zoom in” on this range and let 4 mA correspond to 40% flow, and 20 mA correspond to 60% flow..

4 Installation Modifications

4.1 Change of Flow Direction



Make sure that the system is not pressurized!

After a Flow Meter has been installed in a pipe system, it is possible to swap the flow direction. To do this, always dismount the whole Control Unit including the pressure plate.

Do like this:

1. Unscrew the four hexagon bolts on the top side of the pressure plate.
2. Turn the Control Unit 180° so the arrow on the pressure plate corresponds to the correct flow direction.
3. Remount the hexagon bolts.

It is not possible to dismount only the plastic housing of the Control Unit, since the bolts are running from the rear side of the pressure plate.

4.2 Change of Flow Range

The Eletta Flow Meters features an orifice design that does not require recalibration after exchanging the orifice plate. This can be used in-field for easy change of flow ranges. The orifice plate inside the Pipe Section is the only part that has to be changed.

You can use any flow range and orifice plate that suits your application, as long as the flow falls within the limits of the range for the Flow Meter. See the flow range table in section 7.1.

In each case of changing the orifice plate in-field, we kindly ask you to first contact your distributor or Eletta for advise about the correct orifice plate. The properties of each orifice plate is carefully calculated and designed to match the specific conditions of your installation.

4.2.1 Changing the orifice plate

Perform the following steps for exchanging the orifice plate:

- 1) Dismount the whole Flow Meter.
- 2) Unscrew the orifice plate holder.
- 3) Take out the old orifice plate
- 4) Mount the new orifice plate.
- 5) Mount all removed parts in opposite order.

4.3 Alarm levels

The M-series Flow Meter has one (1) alarm output, with adjustable hystereses, which can be set to trip when a flow has decreased below, or increased above, a certain flow. The alarm levels are pre set at the factory according to customer specification before delivery. If not specified, the default settings are; ON= 51% and OFF=50%. It is also possible though, to readjust the settings in the field using the optional M-WIN software.

The alarm function has two possible settings in order to create suitable hystereses for the actual application, the “ON-and ”OFF”- mode and they can be used as follows;

In the “ON” mode, the voltage level on the output is the same as the supplied power (8 – 28 VDC)

In the “OFF” mode, the voltage drops to zero (0) volt.

Note!!! Please do not set the hystereses with a too small gap as this can create a ripple of the alarm.

Please see example graph below with an assumed power supply of 24Vdc:

Example # 1.

“ON” higher than “OFF”

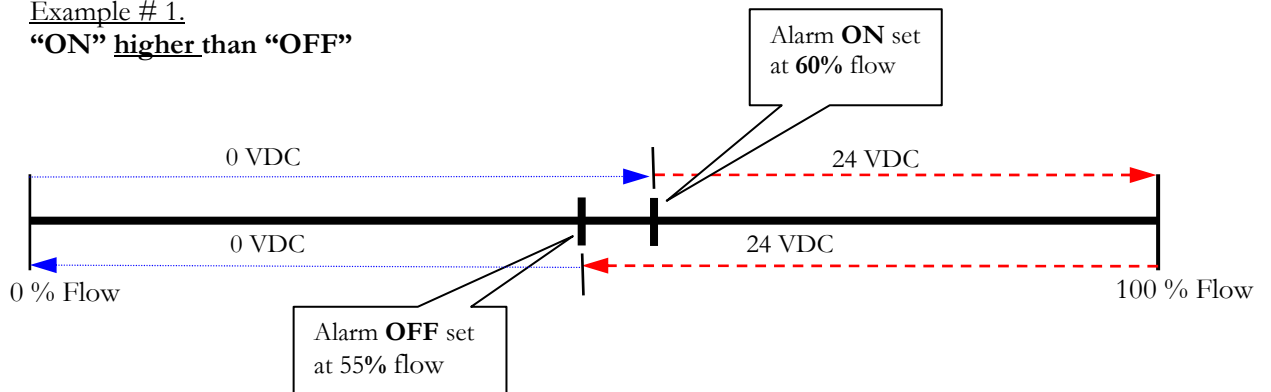

When the flow increases and reach the 60%, the alarm switches at “ON” mode from 0 Vdc to 24Vdc and when the flow decrease and reach the “OFF” mode (55%), the voltage drops to 0 Vdc again.

Example # 2

“ON” lower than “OFF”

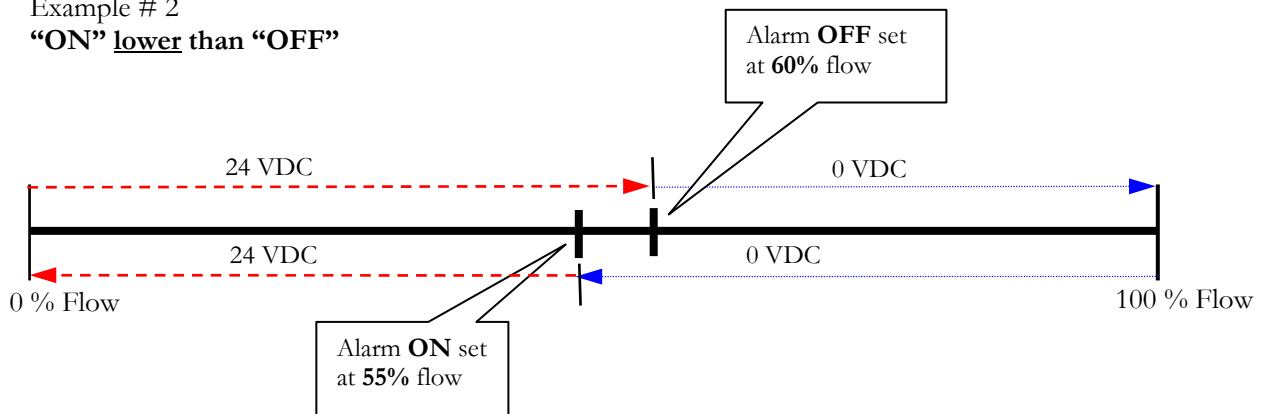

5 Maintenance

As Eletta cannot know the conditions and environmental circumstances at your installation, e.g. surroundings and process media, it is not possible for us to give maintenance recommendations for your specific installation. We can only give the following general maintenance guidelines.

We recommend that you use your own experience with knowledge about the specific installation and environment to decide when periodical inspections should be performed.

5.1 Housing

- Periodically check that the housing has no cracks, and that all seals are tight. This is to prevent moisture and dust to enter inside the housing.

5.2 Electrical wiring and connections

- Periodically inspect the power and output wirings for signs of corrosion, cracks or deterioration.
- Check that the electrical connector to the instrument is tight and shows no signs of corrosion.

5.3 Bolts and screws

- Check that all four visible bolts are present and securely tightened to avoid any leakage. Replace a bolt or screw that has been mechanically damaged.

5.4 Process connection

- Periodically inspect the process pipe connections to verify that all seals are tight and that there are no leakages.
- Check that the Flow Meter is vibrationfree.
- Check that the temperature at the Control Unit does not exceed the maximum temperature of 100° C.

5.5 Pipe Section

- If necessary, periodically remove the Pipe Section and inspect the orifice plate for wear, debris or build-up of foreign material. Any of this could cause inaccurate reading and alarms.
- Check the Pipe Section body for corrosion and stress cracking.

If necessary, clean the bore and the orifice plate using a brush or appropriate solvents (intended for brass or stainless steel; depending on your installation). The sharp edge of the bore is absolutely necessary to provide proper and accurate flow reading. If the bore wear is excessive, please contact your local distributor or Eletta Flow for purchase of a new orifice plate.

6 Trouble Shooting

6.1 Reference flow

If you find that a purchased Eletta Flow Meter does not show the same value as a reference meter on site, this could either be due to that the reference meter has been calibrated under other reference conditions, or that the Eletta Flow Meter now is used under other conditions than the Eletta factory reference conditions.

The accuracy stated is achievable only if the instrument is correctly installed according to this manual.

6.2 FAQ (Frequently Asked Questions)

6.2.1 “The Meter shows the wrong value or nothing at all”

Check the following subjects to find out what is wrong.

Power supply

- Is there any power supply?
- Does the power supply use the correct voltage?
- Is there any output signal, at least 4 mA?
- Is the alarm lead connected correctly? See section 2.5.4

Mounting

- Is the Flow Meter correctly mounted with respect to the flow direction? Check that the engraved arrow on the Pipe Section corresponds to the system media flow.

Flow

- Is there any flow in the system pipe?
- Is the flow sufficient to generate a differential pressure? The Flow Meter is designed for a minimum flow. Check the flow range.

Orifice Plate

- Do you use the correct orifice plate for the application? Check the values on the product label.

Tube Fittings

- If you use "tube fittings" when connecting the system pipes to the Pipe Section, make sure that they do not have inside diameters that are too small. (This could be the case even if the thread size is correct.)

The reason is that such a tube fitting, with an inside diameter that is too small, will create a media jet stream, which results in that the differential pressure gets too low, and thereby causing inaccurate measurement results.

- Verify that you are using the correct inner diameter. See section 2.3 5).
- Are there sufficient straight runs before and after the Flow Meter? We recommend that the run before (upstream) the Flow Meter corresponds to at least 10-15 times the present pipe diameter. The run after (downstream) the Flow Meter should be at least 5 times the diameter. Also make sure that there are no valves, bends or diameter changes. If this is the case, move the Flow Meter so that sufficient straight runs are achieved.

6.2.2 "Liquid (or gas) is coming out of the Control Unit"

- Turn the system flow off. Remove the Flow Meter and check that the Pipe Section and Control Unit have no cracks, and that all seals are tight.

6.3 Electrical connections

- Please make sure that you are using the correct voltage and current.
- Check that all leads are correctly connected.

Do not try to repair the Flow Meter yourself. It is not possible to replace certain spare parts since the Flow Meter has to be calibrated as a whole. Contact your local distributor or Eletta Flow for advise. The product label specifies the serial number, the flow range and the appropriate liquid or gas.

6.4 Spare parts

The Eletta M-series model has no spare parts that can be exchanged. Contact your distributor for information about service.

7 Technical Specification

Size

Type	d	A (mm)	B (mm)	Weight (kg)
M-G15	1/2" BSPP	66	14	0,8
M-G20	3/4" BSPP	69	17	0,9
M-G25	1" BSPP	73	21	1,0

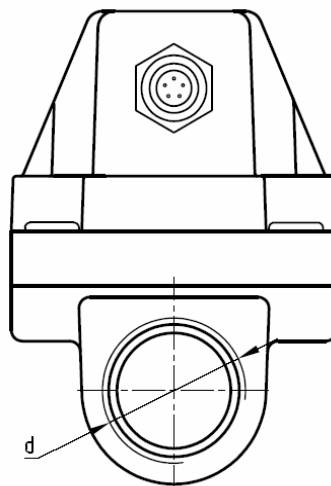
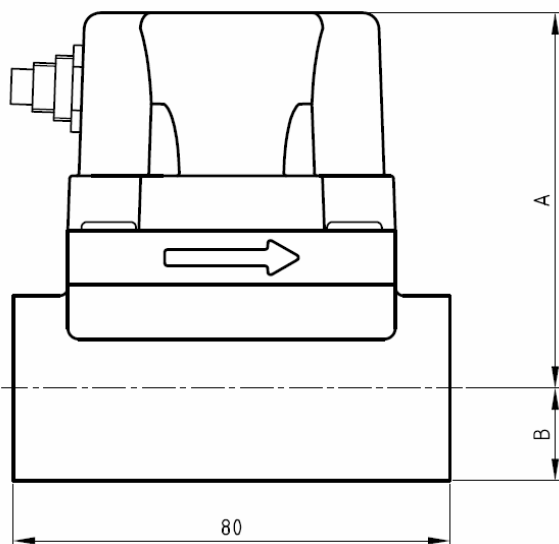
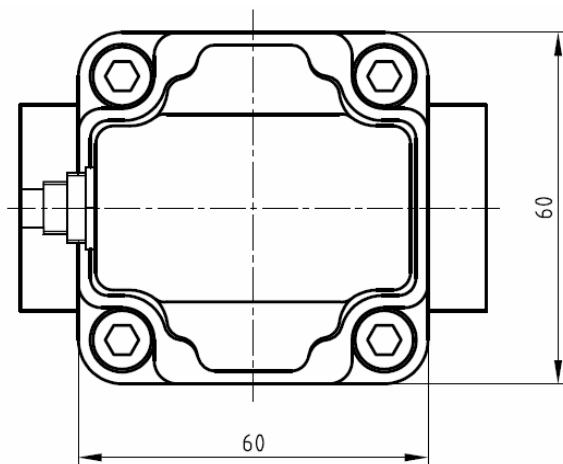

Property	Specification
Accuracy	+/- 1% F.S. of the default set differential pressure (500mbar). This typically corresponds to a flow accuracy of < +/- 2% F.S of the flow range during reference conditions for water and air. Th actual accuracy is depending on the mounting, media and flow profile.
Flow measuring range	1:10 For water and air. For other liquids and gases, depending of viscosity, density and pressure
Repeatability	< 0,5% of present value
Max process pressure	10 bar (145 PSI)
Max overpressure	+50 %
Min pressure*	1 bar (14,5 PSI)
Temperature ranges	<p>Control Unit -10°C to +100 °C (+14 to +212 °F)</p> <p>Compensated Temperature Pressure range -10°C to +80 °C (+14 to + 176°F)</p> <p>For higher process temperatures, it is possible install the Control Unit remotely, see section 2.4.</p>
	<p>Pipe Section SS models -10°C to +200 °C (+14 to +392 °F) BR models -10°C to +120 °C (+14 to +248 °F)</p>
	<p>Connector and included cable Connector -25 to +70 °C (-13 to +158 °F) Included cable -20 to +70 °C (-4 to +158 °F)</p>
Control Unit	<p>Housing PC/ABS plastic with metal plated inside</p> <p>Connector 5 poles Binder 702/712</p>
Connection Cable	PVC cable, 2,5m 3 x 0,25 mm ² (0,00039 inch ²) Resistance < 75 Ω/km IP67
Protection Class	IP67 (NEMA 6)

* Minimum pressure at Flow Meter to get a proper reading, provided there is a flow in the system.

Process Pipe dimensions	DN15-25 (1/2" – 1" BSPP)
Power supply	8 to 28 VDC (2-wire)
Output	<p>4-20 mA (Response time: 10-90 % = 1sec.)</p> <p>RS485 for external computer communication</p> <p>Max output load is calculated with the following formula:</p> <div style="border: 1px solid black; padding: 5px; display: inline-block;"> $\text{Max } \Omega = \frac{\text{Supply voltage} - 8 \text{ V}}{0.02 \text{ A}}$ </div> <p>(incl. Connection Cable)</p>
Alarm output	<p>Transistor type: FET</p> <p>ON mode: +8 to +28 VDC (depending on power supply), 60 mA</p> <p>OFF mode: Approx. 0,1 – 0,5 VDC.</p>
Power consumption	<p>In the range 32 – 560 mW depending on differential pressure and power supply voltage.</p> <p>(Power supply 8 V DC and 4mA output signal: 32 mW Power supply 28 V DC and 20 mA signal: 560 mW)</p>
Pipe Section and Pressure Sensor Housing materials	<p>BR model De-zincificated copper alloy SM2862 (B.S CZ132)</p> <p>SS model Stainless steel SS2353 (ASTM 316L; DIN 1.4435)</p>
Pressure Sensor material	<p>Pressure Sensors Stainless Steel SS2353 (ASTM 316L; DIN 1.4435)</p>
O-rings	<p>BR models NBR (Nitrile Rubber)</p> <p>SS models FPM (Fluorinated rubber)</p>
Sealings material	Dryflex® conductive plastic
Orifice Plate Holder material	Stainless Steel SS2353 (ASTM 316L; DIN 1.4435)
Orifice Plate material	Stainless Steel SS2353 (ASTM 316L; DIN 1.4435)
Explosion proof	The M-series Flow Meter is currently <i>not</i> approved for Ex-hazardous areas.
CE approvals	<p>Eletta Flow Meters conforms with the following EU directives</p> <ul style="list-style-type: none"> • for low voltage, 72/23/EEC (EN 60 204-1 Part 1) • for electromagnetic compatibility, 89/336/EEC (EN 61 000 - 6-2:2001-1 and 6-3:2001)

7.1 Measurement flow ranges (liquids)

The following table states the standard flow ranges for the M-series models.

Model	l/min	US Gpm
M-G15BR M-G15SS	0-2	0-0,5
	0-5	0-1
	0-10	0-2,5
	0-40	0-10
M-G20BR M-G20SS	0-10	0-2,5
	0-50	0-10
	0-75	0-20
M-G25BR M-G25SS	0-10	0-2,5
	0-50	0-10
	0-100	0-25

7.2 Type plates

On each flow meter you find two type plates stating technical data for your specific flow meter. Examples of type plates are shown below.

The largest plate is the main type plate which states:

- type
- model
- power supply range
- output signal range
- serial No
- temperature range
- max pressure
- protection class

ELETTA		Phone: +46 8 603 0770 www.eletta.com
Type: M-G25BR	Min. / Max. Temperature: 0-100 °C	
Model: 223011025	Max. Pressure: 10 bar (g)	
Supply: 8-28 Vdc	Protection Class: IP67	
Output: 4-20 mA	 2004	
No.: Demo		

The second plate states the flow conditions for the specific orifice plate:

- fluid
- specific gravity
- viscosity
- temperature
- pressure
- flow range
- differential pressure range

FLOW CONDITIONS	
Fluid: Water	S.G.: 1,0
Viscosity:	1 cSt
Temperature:	°C
Pressure:	bar (g)
Q _{Range} :	0-50 l/min
Δp _{Range} :	0-500 mbar

On the cable at the open end you find a sticker with the wiring diagram

Wiring diagram

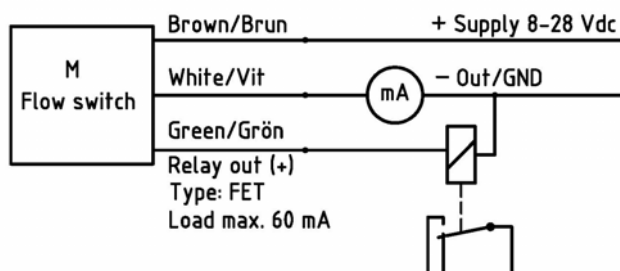

8 Exploded diagram

Control Unit

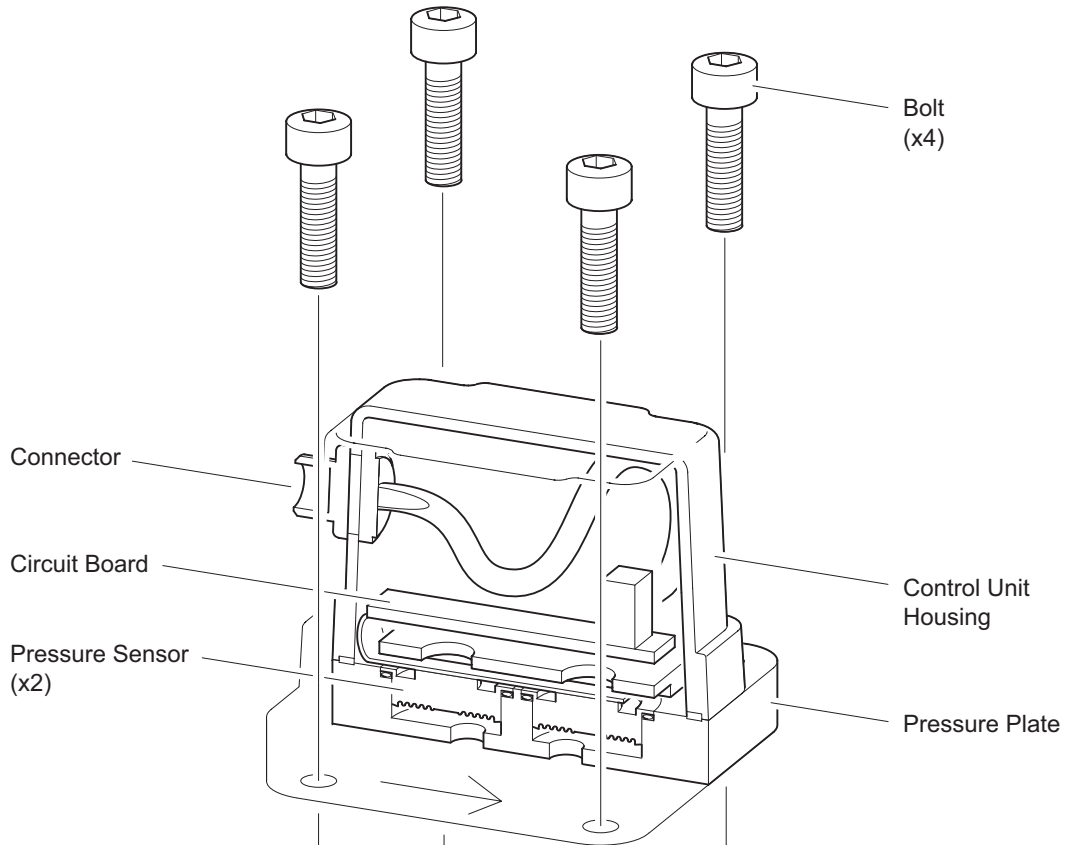

Pipe Unit

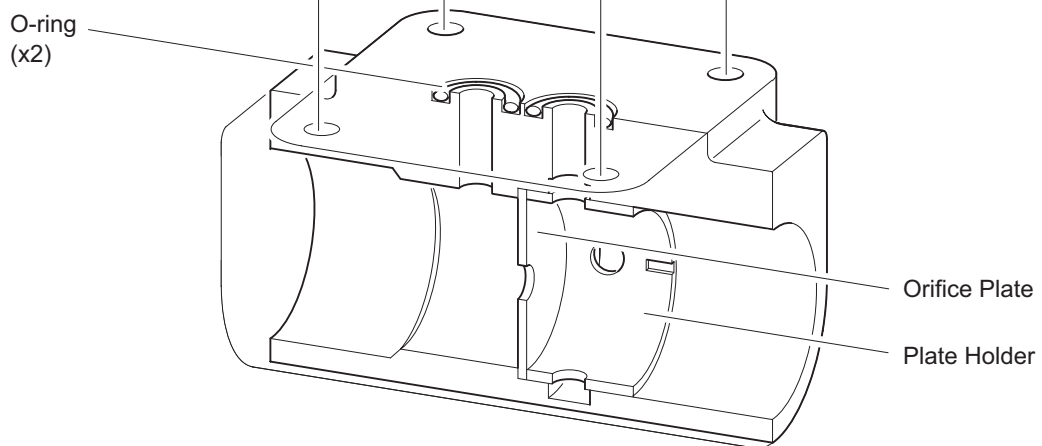

620A2E5

Control Unit and Pressure Plate

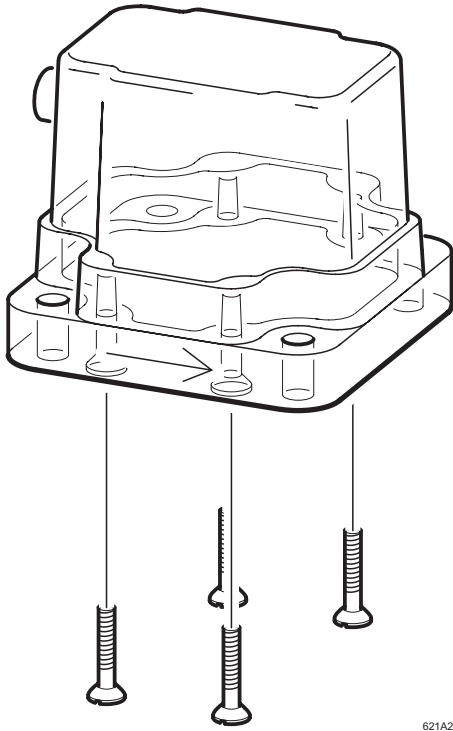

621A2E5

M6 holes for rigid mounting

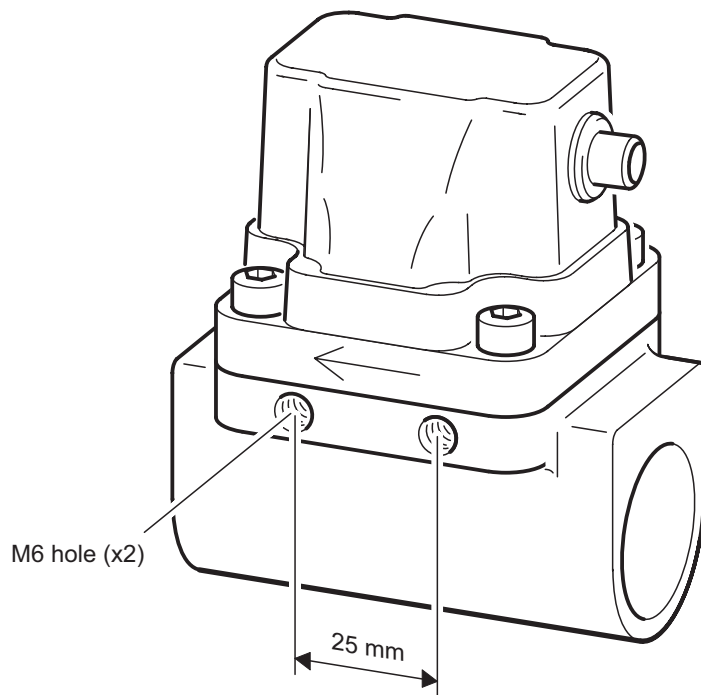

622A2E5

Eletta Flow AB
P.O. Box 5084
SE-141 05 Huddinge
SWEDEN

E-mail info@eletta.com
www.eletta.com
Phone + 46 8 603 07 70 Switchboard
+ 46 8 603 07 80 Orders and Inquires
Fax + 46 8 646 10 40