



**- REGOLATORE
- CONTROLLER**

ATR400

**Manuale Installatore
User Manual**

Sommario

1 - INTRODUCTION.....	1	15 - INTRODUZIONE.....	32
2 - ORDERING CODES	1	16 - IDENTIFICAZIONE DEL MODELLO	32
3 - TECHNICAL DATA.....	2	17 - DATI TECNICI	33
3.1 - Main features	2	17.1 - Caratteristiche generali.....	33
3.2 - Hardware data	2	17.2 - Caratteristiche hardware.....	33
3.3 - Software data.....	3	17.3 - Principali caratteristiche software.....	34
4 - SIZES AND INSTALLATION	3	18 - DIMENSIONI E INSTALLAZIONE	34
5 - ELECTRICAL WIRINGS.....	4	19 - COLLEGAMENTI ELETTRICI.....	35
5.1 - Wiring plan.....	4	19.1 - Schema di collegamento.....	35
6 - DISPLAYS AND KEYS.....	9	20 - FUNZIONE DEI VISUALIZZATORI E TASTI40	
6.1 - Displays	10	20.1 - Indicatori numerici (display)	41
6.2 - Meaning of leds.....	10	20.2 - Significato delle spie di stato (led).....	41
6.3 - Keys.....	11	20.3 - Tasti	42
7 - SOFTWARE FUNCTIONS	12	21 - FUNZIONI DEL REGOLATORE	43
7.1 - Automatic/manual control.....	12	21.1 - Regolazione automatico/manuale.....	43
7.2 - Loop Break Alarm	13	21.2 - Loop Break Alarm	44
7.3 - Auto-tuning	14	21.3 - Auto-tune.....	45
7.4 - Manual Tuning	14	21.4 - Tuning manuale.....	45
7.5 - Autotuning.....	14	21.5 - Tuning automatico	45
7.6 - Delayed start.....	15	21.6 - Attesa inizio regolazione	46
7.7 - Soft Start.....	16	21.7 - Soft Start	47
7.8 - Memory Card	16	21.8 - Memory Card.....	47
8 - CONFIGURATION	17	22 - CONFIGURAZIONE.....	48
8.1 - Modify configuration parameter.....	17	22.1 - Modifica parametro di configurazione..	48
9 - TABLE OF CONFIGURATION PARAMETERS.....	19	23 - TABELLA PARAMETRI DI CONFIGURAZIONE	50
10 - ALARMS OPERATING.....	26	24 - MODI D'INTERVENTO ALLARME	57
11 - PROTOCOL MODBUS RTU	27	25 - PROTOCOLLO DI COMUNICAZIONE MODBUS RTU	58
11.1 - General features	27	25.1 - Caratteristiche	58
12 - WORD ATR400.....	28	25.2 - Indirizzi word ATR400.....	59
13 - ERROR MESSAGES	30	26 - TABELLA SEGNALAZIONI ANOMALIE	61
14 - CONFIGURATION PLAN.....	31	27 - PROMEMORIA CONFIGURAZIONE	62

1 - INTRODUCTION

The controller ATR400 integrates control functions for process automation. All versions are provided with serial communication RS485 and Modbus/RTU protocol. The controller maintains the distinctive features of all Pixsys instruments as free configurable input and a wide range of parameters to make it easily adaptable and highly flexible.

To simplify the configuration, a special **memory-card** has been conceived to copy all parameters at the starting and eventually store them for historical archive.

Sealing of cover according to IP54. Frontal extraction of electronics.

2 - ORDERING CODES

The controller ATR400 is available in different versions. The table below allows to choose the required model.

Ordering codes

ATR400-	<input type="checkbox"/>	<input type="checkbox"/>	<input type="checkbox"/>	
Inputs	1			1 Input TC-RTD-V-mA + TA 50mA
Outputs	1			2 relays + 1 output 0...10V/4...20mA
	2			3 relays (Out3 parallel to SSR)
Power supply		AD		12/24V AC $\pm 15\%$ 50/60Hz (with selection by internal Jumpers)
		BC		230/115V AC $\pm 15\%$ 50/60Hz (with selection by internal Jumpers)

3 - TECHNICAL DATA

3.1 - Main features

Visualizers	2 displays, 4 digits - 0,56 inches
Operating conditions	0-45°C, humidity 35..95uR%
Sealing	IP54 Frontal
Material	ABS UL94V0 self-extinguish
Weight	450g

3.2 - Hardware data

Analogic inputs	1: AN1, Software configurable	Accuracy (25°C) 0.2% ± 1 digit for input TC, RTD, V, mA
	Input no.1 Thermocouples K, S, R, J RTD PT100, Ni100 Linear Input 0...10V, 0...20mA, 4...20mA	
Relay outputs	2/3 relays: OUT1, OUT2, OUT3	
	Configurable for control and/or alarm.	Contacts 8A-250V~ resistive
Linear outputs	1 Linear output Configurable for control or setpoint/process retransmission.	Configurable as 0...10V or 4...20mA.
	Serial communication	
Serial communication	1: RS485 Serial communication with Modbus protocol.	
Input TA	1: Amperometric transformer 50mA Configurable current with operating treshold	
Digital input	1: IN1 Configurable for block signal and/or Setpoint switch.	

3.3 - Software data

Control action	ON-OFF with hysteresis. P, PI, PID, PD time proportioning.
Proportional band	0...9999 °C or °F or "measure unit"
Integral time	0...9999 sec (0 excludes Integral)
Derivative time	0,0...999,9 sec (0 excludes Derivative)
Software functions	Manual or automatic Tuning, Loop break alarm (excessive load), Configurable alarms, Protection Set2, Delayed start.

4 - SIZES AND INSTALLATION

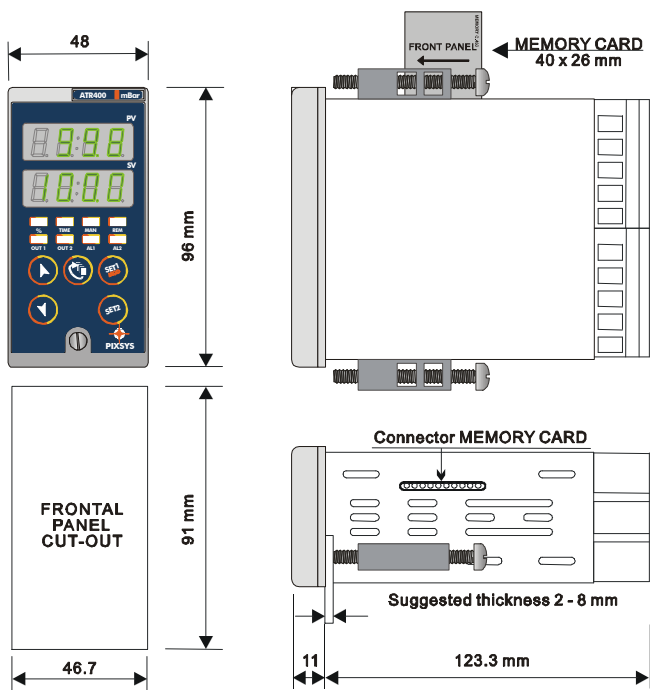

5 - ELECTRICAL WIRINGS



Although this controller has been conceived to resist the worst noises in an industrial environment, please notice the following safety guidelines:

- Separate control wires from power wires
- Avoid mounting close to remote control switching systems, electromagnetic relays, powerful engines
- Avoid proximity of power systems, especially those with phase control.

5.1 - Wiring plan

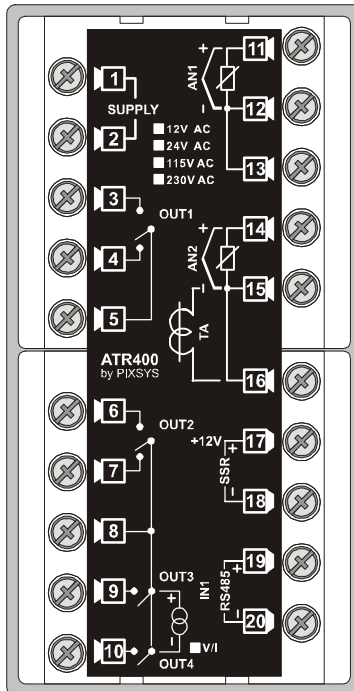

Power supply

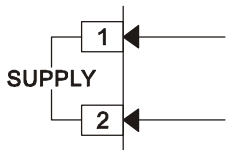

- 12/24Vac $\pm 15\%$ 50/60Hz
(selection by internal jumper)
- 230/115Vac $\pm 15\%$ 50/60Hz
(selection by internal jumper)

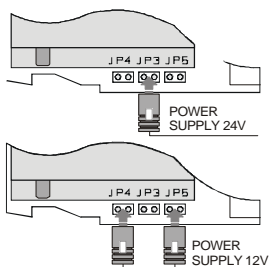

Version ATR400-xxAD

- Select JP4 and JP5 for **12V AC**
- Select JP3 for **24V AC**

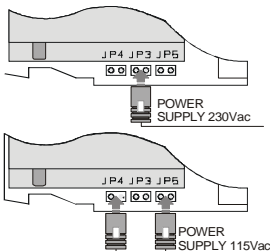

Version ATR400-xxBC

- Select JP4 and JP5 for **115V AC**
- Select JP3 for **230V AC**

Analogic input



Thermocouples K, S, R, J

- Respect polarities.
- For eventual extensions, use the compensating cable and terminals suitable for the used thermocouple

	<p>RTD type PT100, NI100</p> <ul style="list-style-type: none"> For a three-wire wiring use cables with the same diameter. For a two-wire wiring short-circuit pins 12 and 13.
	<p>For output V, mA</p> <ul style="list-style-type: none"> Respect polarities.
<p>PRESSURE TRANSMITTER</p>	<p>For signals 0/4...20mA with three-wires sensor.</p> <p>Respect polarities A= Sensor output B= Sensor ground C=Sensor Supply</p>
<p>PRESSURE TRANSMITTER</p>	<p>For signals 0/4...20mA and sensor with external power supply.</p> <p>Respect polarities A=Sensor output B=Sensor ground</p>
<p>PRESSURE TRANSMITTER</p>	<p>For signals 0/4...20mA with two-wires sensor.</p> <p>Respect polarities A= Sensor output C= Sensor Supply</p>

Serial input

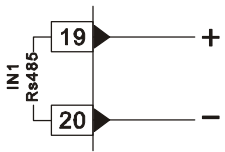
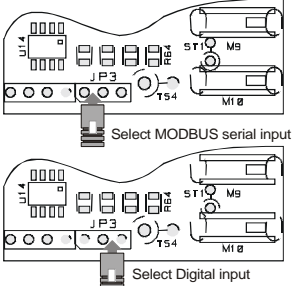
	<ul style="list-style-type: none"> • RS485 Modbus communication • Digital block input , configurable from parameter 22 SER. as N.O. and N.C.
 <p>Select MODBUS serial input</p> <p>Select Digital input</p>	<ul style="list-style-type: none"> • Set jumper JP3 as in the table beside to select serial or digital input.

Input TA

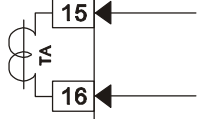
	<ul style="list-style-type: none"> • Input for amperometric transformer 50mA. • Sampling interval 100ms. • Configurable by parameters.
---	---

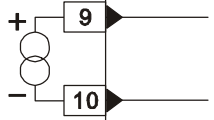
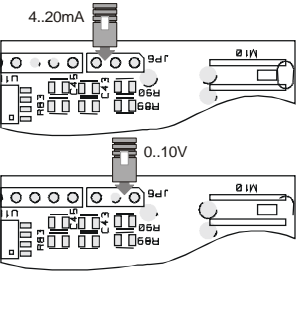

Linear output

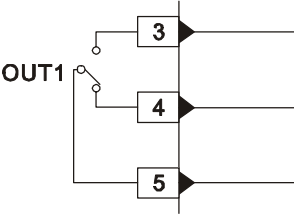
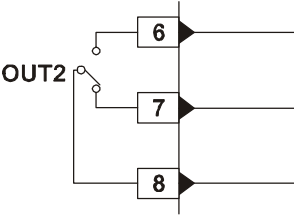
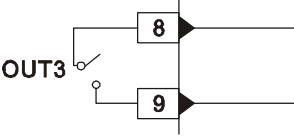
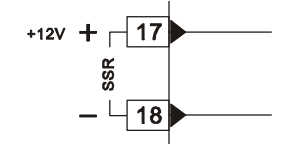



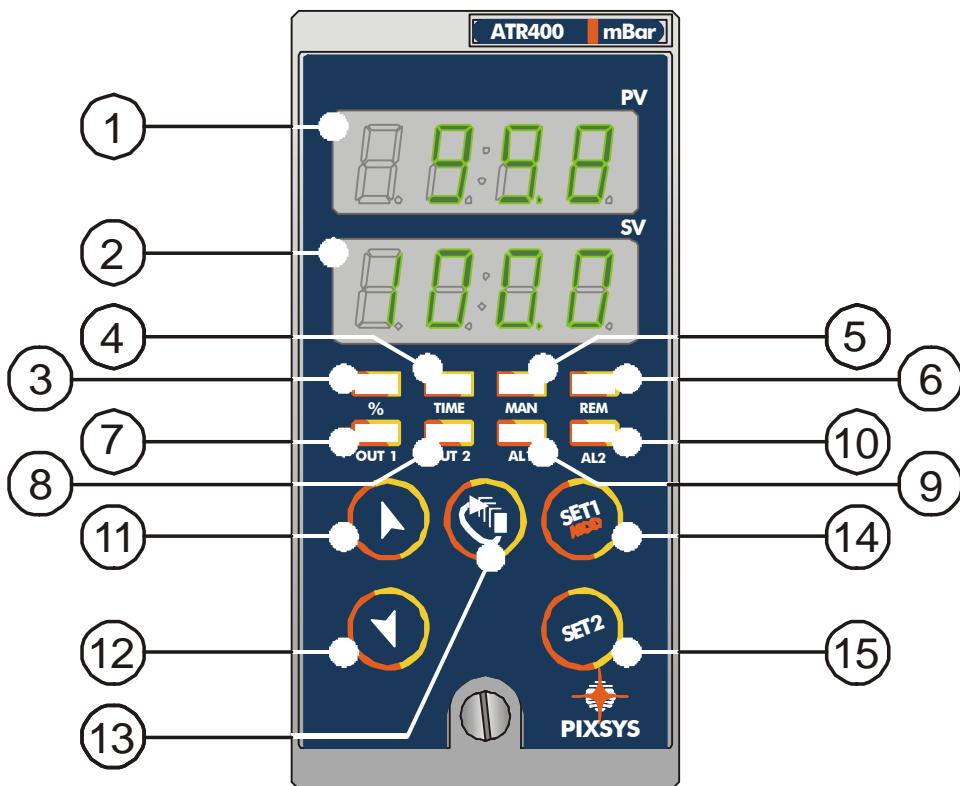



	<ul style="list-style-type: none"> • Linear output configurable by parameters and jumpers as 0...10V / 2...10V o 4...20mA (Opto-isolated)
 <p>4..20mA</p> <p>0..10V</p>	<ul style="list-style-type: none"> • Set jumper JP6 as in the table beside to select 0...10V / 2..10V o 4...20mA

Relay output and SSR (Parameter 1 <input type="text" value="cout1"/>	
 <p>OUT1</p>	<p>Contacts capacity 8A/250V~ resistive <u>Possible configurations:</u></p> <ul style="list-style-type: none"> • Control relay with parameter P-1 <input type="text" value="cout1"/> set as <input type="text" value="out1"/> • Valve opening for configuration Open/Close <input type="text" value="SERU"/> • Alarm relay 1 with <input type="text" value="SSr"/> and linear outputs control.
 <p>OUT2</p>	<p>Contacts capacity 8A/250V~ resistive <u>Possible configurations:</u></p> <ul style="list-style-type: none"> • Valve closing for configuration Open/Close <input type="text" value="SERU"/> • Alarm relay 2 with control of <input type="text" value="out1"/>, <input type="text" value="SSr"/> and linear outputs.
 <p>OUT3</p> <p>*Only for ATR 400-12xx Parallel to output SSR</p>	<p>Contacts capacity 8A/250V~ resistive. <u>Possible configurations</u></p> <ul style="list-style-type: none"> • Control output with configuration <input type="text" value="SSr"/> • Alarm 1 with control output <input type="text" value="out1"/> • Alarm 2 with configuration Open/Close <input type="text" value="SERU"/> or control of linear output
 <p>+12V +</p> <p>- SSR</p>	<p>CAPACITY 12V/30M <u>Possible configurations:</u></p> <ul style="list-style-type: none"> • Control output with configuration <input type="text" value="SSr"/> • Alarm 1 with control <input type="text" value="out1"/> • Alarm 2 with configuration Open/close <input type="text" value="SERU"/> and control of linear output











6 - DISPLAYS AND KEYS



6.1 - Displays		
1		It usually visualizes the process value (the value read by the sensor). During configuration it visualizes the number of entering parameter. It can visualize also the value of absorbed current if function Loop Break Alarm is enabled.
2		This display can visualize setpoint values, output percentage and automatic/manual selection. During the configuration, the value of entering parameter is visualized.

6.2 - Meaning of leds		
3		Flashing to indicate the percentage of P.I.D.
4		Flashing during the programming of waiting time . ON during the waiting
5		The led flashes during the programming of automatic/manual control. ON when Manual operating is enabled.
6		ON when the controller is answering a serial polling.
7		ON when control output is active. In case of Open/Close functioning, led is ON when valve is opening.
8		In case of Open/Close functioning, led is ON when valve is closing.
9		ON when alarm 1 is active.
10		ON when alarm 2 is active.









6.3 - Keys

11		<ul style="list-style-type: none">• Modify setpoint values when pressed after or with key  or key .• Scroll parameters in configuration mode. Modify parameters value if pressed with key • Modify output percentage during Manual operating.• Select automatic/manual operating.• Modify the value of the timer
12		<ul style="list-style-type: none">• Modify setpoint values when pressed after or with key  or .• Scroll parameters in configuration mode. Modify parameters value if pressed with key • Modify output percentage during Manual operating.• Select automatic/manual operating.• Modify value of timer.
13		<ul style="list-style-type: none">• Enter or exit the configuration mode.• Scroll functions of the controller: modify output percentage, select automatic/manual operating, settings of timer and visualization of setpoint.
14		<ul style="list-style-type: none">• Modify setpoint 1.• Modify configuration parameters.
15		<ul style="list-style-type: none">• Visualize / Modify setpoint 2.

7 - SOFTWARE FUNCTIONS

7.1 - Automatic/manual control

This function allows to select manually the output percentage or the automatic operation according to selected parameters.

	Press	Display	Do
1		This key allows to scroll on display 2 the following values: output percentage, , waiting time (if enabled) auto/man function and setpoint.	Press  until  starts flashing.
2	 	Select <input type="text" value="on"/> or <input type="text" value="off"/> .	
3		Press the key, until the led  starts flashing. Display 2 visualizes the output percentage	Press   to modify the output percentage (manual mode).

7.2 - Loop Break Alarm

This function allows to measure load current to handle an alarm in case of malfunction with short-circuited or open actuator (SSR or thyristor). The value of the amperometric transformer connected on pins 15 and 16 must be 50mA (sampling interval 100ms).



- Set on parameter 13 **EA** the amperometric value of transformer .
- Enter on parameter 14 **ALFA** the operation treshold for Loop Break Alarm.
- One relay can be used for alarm by entering on parameter 15 **AL. 1** or 18 **AL. 2**, the value **ALFA**.

In case that a contactor or a SSR should keep closed, the controller visualizes **brfc**.

as error message. If the contactor or SSR stays open, the controller visualizes **brfo**.

Alarm status stops as soon as anomaly stops

It is possible to visualize the current absorbed during the closing stage.



	Press	Display	Do
1		This key allows to scroll on display 2 the following values: output percentage, , waiting time (if enabled) auto/man function and setpoint.	Press  until led  starts flashing. Display 1 visualizes the current (if function L.B.A. is active) and value remains even when load current is not registered.

7.3 - Auto-tuning

The Autotuning function for the optimal rating of PID parameters can be started manually or it can be automatic ⁽¹⁾ at each starting of the controller or after any change of setpoint value.

7.4 - Manual Tuning

Manual Tuning (enabled by parameter 21 `tune`) can be started only when the controller visualizes process and setpoint. To avoid overshoot, it is strongly recommended to start it only if process value is **35%** lower than setpoint value.



	Press	Display	Do
1	Press first  and then  .	Display 2 visualizes alternatively the setpoint and the writing <code>tune</code> .	Wait until the visualization of the writing <code>tune</code> stops. To stop the function press  .







7.5 - Autotuning

Automatic Tuning (enabled on parameter 21 `tune`) is activated at each starting of the controller or when setpoint is modified more than 35% of its value. Display 2 visualizes alternating setpoint value and the writing `tune`. Press  to interrupt the function keeping the PID parameters unchanged

(1) Access of the operator to this function can be denied by the installer. (See point 9, Parameter-21).

7.6 - Delayed start

This function allows to set a delayed start of the controller. The relevant parameter to enable the function is P-25 . If a time value has been entered, at the starting the led  is ON.

	Press	Display	Do
1		This key allows to scroll on display 2 the following values: output percentage, , waiting time (if enabled) auto/man function and setpoint.	Press  until led  starts flashing.
2	 	Modify the waiting time visualized on display 2.	During waiting time press  to quit the function. Switch the controller off and restart it to reactivate the waiting function.

7.7 - Soft Start







This function enables the programming of a rise gradient (set as degrees/hour) to reach the setpoint value.

Set on parameter 26 the chosen value: at next restarting, the controller will execute the function Soft Start.

If automatic Tuning is enabled, the function Soft Start will automatically be disabled. If manual Tuning is started while the function is in progress, the Soft Start will be interrupted.

7.8 - Memory Card

Parameters and cycle values can be copied and stored on another controller by means of the Memory Card. Before you insert the Card, **the controller must be switched-off** . Please **check also entry direction** (see label on the Card) . When the controller is switched-on, display 1 visualizes and display 2 visualizes ¹.

	Press	Display	Do
1	 	 visualizes <input type="text" value="YES"/> ,  visualizes <input type="text" value="no"/> .	Select <input type="text" value="YES"/> if values stored on the Memory Card must be loaded on the controller. Selecting <input type="text" value="no"/> the data of the controller will be kept unchanged.
3		The controller loads the value and the beep of internal buzzer confirms that data have been copied. Controller is ready	

¹ If data stored on Memory Card are correct.









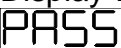

Updating of Memory Card.

See also previous point, select  on display 2 to update the values of Memory Card ². Enter configuration mode and **change at least one parameter**. Quitting the configuration mode, the beep of internal buzzer will confirm that new values have been stored.



8 - CONFIGURATION

8.1 - Modify configuration parameter

To modify configuration parameters (see chap. 9), the controller must be visualizing process and setpoint.

	Press	Display	Do
1	Keep pressing  for about 5 sec.	Display 1 visualizes  and the 1 st digit flashes. Display 2 visualizes 	
2	  and 	Modify the flashing digit and move to next digit.	Enter password 
3		Display 1 visualizes the code of first parameter. Display 2 visualizes the value of parameter.	
4	 	Scroll through the parameters	

² In case that the controller does not visualize , this means that no data are stored on the Card, but values can be updated

5		<p>Increase or decrease the visualized value:  and then one of the arrow-keys.</p>	<p>Enter new value. To modify another parameter, go back to point 4.</p>
6		<p>End of configuration. The controller exits the programming mode.</p>	



9 - TABLE OF CONFIGURATION PARAMETERS

N.	Display	Description	Range
1	<code>c.out</code>	<p>This parameter defines the configuration of all outputs available on the controller. The options visualized on display 2 correspond to the main control output (relay, SSR, 0..10/2..10V, 4..20mA, valve Open/Close). Each selection corresponds also to a different configuration of the secondary outputs available as alarms (and configurable on parameters 15...19).</p> <p>(If control output is selected as 0..10,2..10, 4..20 : extract the electronics from panel , find out Jumper JP6 and place it correctly as described on page 7)</p>	<p><code>out 1</code> : out1 control SSR* alarm 1 out 2 alarm 2</p> <p><code>SSr</code> : SSR* control out1 alarm 1 out2 alarm 2</p> <p><code>SEru</code> : out1(open)+out2(close) valve control SSR* alarm 2</p> <p><code>c.0.10</code> : control 0..10V out1=alarm 1 out2+SSR* = alarm 2</p> <p><code>c.2.10</code> :control 2..10V out1= alarm 1 out2+SSR* = alarm 2</p> <p><code>c.420</code>:control 4..20mA out1= alarm 1 out2+SSR* =alarm 2</p> <p>N.B.: <code>c.0.10</code>, <code>c.2.10</code> and <code>c.420</code> can be selected only on model ATR400-11XX.</p>

*SSR parallel to OUT3 on version ATR400-12XX

N.	Display	Description	Range
2	SEn	Configuration of analogic input	Ec. T : (-260°...1360°C) Thermocouple K Ec. S : (-40°...1760°C) Thermocouple S Ec. R : (-40°...1760°C) Thermocouple R Ec. J : (-200°...1200°C) Thermocouple J Pt : PT100 (-50°...800°C) Pt 1 (with decimal point) PT100 (-50.0°...800.0°C) ni : NI100 (-50°...200°C) ni 1 (with decimal point) NI100 (-50.0°...200.0°C) 0.10 : 0...10V no decimal 020 : 0...20mA no decimal 420 : 4...20mA no decimal 0.10.1 : 0...10V one decimal 020.1 : 0...20mA one decimal 420.1 : 4...20mA one decimal
3	inF.	Lower limit of scale	-999...+9999 digit or -99.9...+999.9 digit
4	SuP.	Upper limit of scale	-999...+9999 digit or -99.9...+999.9 digit

N.	Display	Description	Range
5	HYS.	Hysteresis (delay on the activation of control output)	-999...+999 digit
6	cALo.	Offset calibration (This value is added to the visualized process value , usually correcting the ambient temperature)	-150...+150 units
7	cALG.	Gain calibration (The visualized value is multiplied for this % to calibrate process value)	-10.0%...+10.0%
8	rEG.	Type of control action	cold : cold (n.c.) Hot : heat (n.a.)
9	Pb.	Proportional band. Inertia of process expressed as units (°C if temperature)	0 on/off 1-9999 digit
10	t.i.	Integral time Inertia of process expressed as seconds	0-9999 seconds (0 integral disabled)
11	t.d.	Derivative time Usually ¼ of Integral time	0.0-999.9 seconds (0 derivative disabled)
12	t.c.	Duty cycle or cycle time (10/15sec for PID with contactors, 1 sec for PID with SSR) or servomotor time (time value declared by the manufacturer of the valve)	1-120 seconds
13	tA.	Enable amperometric transformator and setting of the range	0 T.A disabled 1-200 Ampere
14	ALtA.	Treshold for the activation of Loop Break Alarm	0-200 Ampere

15	AL. 1	<p>Operating of alarm1 The setpoint for this alarm is fixed on parameter 16.</p>	<p>AL.A : absolute referring to process AL.B : band (ex. If Set is fixed as 5°C, output will be activated 5° above and 5° below the value of main set). AL.D.S : upper deviation (ex. If Set is fixed as 5°C, output will be activated 5° above the value of main set). AL.D.L : lower deviation (ex. If Set is fixed as 5°C, output will be activated 5° below the value of main set) AL.A.S : absolute referring to setpoint 1 AL.B.A : Loop Break Alarm</p>
16	AL. 1	<p>Treshold for alarm1 While setpoint for control action and alarm 2 can be modified by frontal keys  and , the setpoint for alarm 1 is fixed by this parameter and therefore it can be modified only in configuration mode.</p>	<p>-999...+9999 digit -99.9...+999.9 digit</p>

N.	Display	Description	Range
17	A lcr.	Relay contact of alarm 1	no. : Normally open nc. : Normally closed
18	AL 2	Select operating of alarm2 Setpoint of alarm 2 is defined by SET2.	ALA : absolute referring to process ALb. : band ALdS. : upper deviation ALd. : lower deviation ALAS. : absolute referring to setpoint 1 ALtA. : Loop Break Alarm
19	A2cr.	Relay contact of alarm 2	no. : Normally open nc. : Normally closed
20	PSE2	Protect Set2	FrEE : Set 2 can be modified by frontal keys Prot. : SET2 can be modified only in configuration mode
21	tunE	Select Tuning mode	oFF : disabled Auto : automatic start MAN : manual start

N.	Display	Description	Range
22	SEr.	Select digital or serial input Select JP3 as in the picture on page 8	ndb.1 : baud rate 38400 ndb.2 : baud rate 19200 ndb.3 : baud rate 9600 ndb.4 : baud rate 4800 b.ina : block input N.O. Control output is disabled b.inc : block input N.C. Control output is disabled SSna select control set N.O. Change control setpoint (switch from Set1 to Set2) SSnc : select control set N.C. Change control setpoint (switch from Set1 to Set2)
23	Addr.	Slave address	1-99
24	r it.	Delay Modbus	0-250 ms
25	t iNE	Enable timer for waiting function	oFF :timer disabled UR it :timer enabled
26	SoFt	Soft start (available up Version 2.0)	0 disabled 1-1000 degrees/hour
27	GrAd.	Select degrees	oC : Celsius oF : Fahrenheit

N.	Display	Descrizione parametro	Range di inserimento
28	cont.	<p>Retransmission for linear output (Jumper JP6 must be set correctly for linear output)</p> <p>Parameters 3 and 4 define the lower and upper limits of the scale.</p> <p>N.B. Retransmission is not available if parameter 1 <code>SEn</code> is configured as control output</p>	<p><code>oFF</code>: disabled</p> <p><code>0.105</code>:retrasm. Set1</p> <p><code>4205</code>:retrasm. Set1</p> <p><code>0.10A</code>:retrasm. Set2</p> <p><code>420A</code>:retrasm. Set2</p> <p><code>0.10P</code>:retrasm.</p> <p>Process</p> <p><code>420P</code>:retrasm.</p> <p>Process</p>

10 - ALARMS OPERATING

Band alarm (setpoint-process)

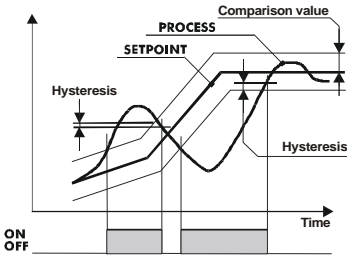

- The alarm can be:
- working outside
 - working inside

Example: Outside

Deviation alarm (setpoint-process)

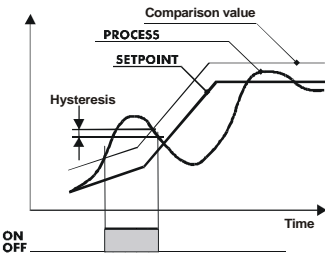

- The alarm can be:
- Upper deviation
 - Lower deviation

Example: Upper deviation

Independent alarm (process)

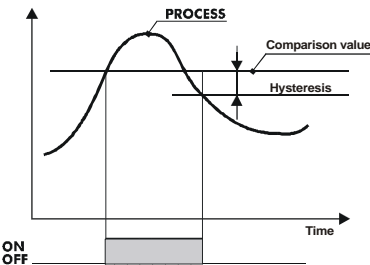

- The alarm can be:
- working over
 - working under
- Example: working over

11 - PROTOCOL MODBUS RTU

11.1 - General features

ATR400 is conceived for use and remote connection via Modbus protocol. Serial communication RS485 enables the programming of configuration parameters, inputs, outputs and the reading of input sensor.

Baud-rate	Configurable by parameters 38400 bits/sec 19200 bits/sec 9600 bits/sec 4800 bits/sec
Format	8, N, 1(8bit, no parity, 1 stop)
Supported functions	WORD READING (max 1 word) (0x03, 0x04) SINGLE WORD WRITING (0x06)

N.B.

For further details about serial communication, please ask for data sheet no. AN-0014-xxxx.

12 - WORD ATR400			
MODBUS ADDRESS	DESCRIPTION	READ/WRITE	RESET VALUE ¹
1	Process	R	?
2	Cold junction temperature	R	?
3	Setpoint 1	R/W	EEP
4	Setpoint 2	R/W	EEP
5	Value of proportioning output	R/W	?
6	Select automatic/manual	R/W	EEP
7	Waiting time/Delayed start	R/W	EEP
8	Current T.A.	R	0
9	Parameter 1 <input type="text" value="cout"/>	R/W	EEP
10	Parameter 2 <input type="text" value="SEn"/>	R/W	EEP
11	Parameter 3 <input type="text" value="inF."/>	R/W	EEP
12	Parameter 4 <input type="text" value="SuP."/>	R/W	EEP
13	Parameter 5 <input type="text" value="HYS."/>	R/W	EEP
14	Parameter 6 <input type="text" value="cALd."/>	R/W	EEP
15	Parameter 7 <input type="text" value="cALD."/>	R/W	EEP
16	Parameter 8 <input type="text" value="rEG."/>	R/W	EEP
17	Parameter 9 <input type="text" value="Pb."/>	R/W	EEP
18	Parameter 10 <input type="text" value="t.i."/>	R/W	EEP
19	Parameter 11 <input type="text" value="t.d."/>	R/W	EEP
20	Parameter 12 <input type="text" value="t.c."/>	R/W	EEP
21	Parameter 13 <input type="text" value="t.R."/>	R/W	EEP

¹ According to initialization value at starting, the following possibilities are given:

1. "EEP" Value stored on EEprom.
2. "?" Values not known at starting

MODBUS ADDRESS	DESCRIZIONE	READ/WRITE	RESET VALUE
22	Parameter 14 ALTA	R/W	EEP
23	Parameter 15 AL. 1	R/W	EEP
24	Parameter 16 AL. 1	R/W	EEP
25	Parameter 17 A1cr.	R/W	EEP
26	Parameter 18 AL. 2	R/W	EEP
27	Parameter 19 A2cr.	R/W	EEP
28	Parameter 20 PSE2	R/W	EEP
29	Parameter 21 tunE	R/W	EEP
30	Parameter 22 SEr.	R/W	EEP
31	Parameter 23 Addr.	R/W	EEP
32	Parameter 24 r it.	R/W	EEP
33	Parameter 25 t iNE	R/W	EEP
34	Parameter 26 SoFT	R/W	EEP
35	Parameter 27 CrAd.	R/W	EEP
36	Parameter 28 cont.	R/W	EEP
37	Enable regulation	R/W	0
50	Byte Display1 (4° digit)	R	EEP
51	Byte Display1 (3° digit)	R	EEP
52	Byte Display1 (2° digit)	R	EEP
53	Byte Display1 (1° digit)	R	EEP
54	Byte Display2 (4° digit)	R	EEP
55	Byte Display2 (3° digit)	R	EEP
56	Byte Display2 (2° digit)	R	EEP
57	Byte Display2 (1° digit)	R	EEP
58	Byte Led	R	EEP
59	Byte keys	W	EEP

13 - ERROR MESSAGES

In case the plant does not work properly, the controller stops the program running and shows a fault condition, activating the internal buzzer. To stop the buzzer press any key.

Example: the controller will notify a broken thermocouple visualizing **E-05** flashing on display. See table below for description of fault messages.

#	Cause	Do
E-01	Programming error E ² PROM.	-
E-02	Cold junction sensor failure or ambient temperature out of range	-
E-04	Wrong configuration data. Possible lost of calibration values	Check configuration parameters.
E-05	Open sensor or temperature out of range	Check connection of sensor
b r f o	Loop break alarm. Current circuit open	Check contactors, SSR...
b r f c	Loop break alarm. Short-circuit	Check contactors, SSR...

14 - CONFIGURATION PLAN

Date:

Modell ATR400:

Notes:

cout	Select control output	
SEn	Configuration analogic input AN1	
inf.	Lower limit of scale	
Sup.	Upper limit of scale	
HYS.	Hysteresis for operating treshold of outputs	
cALo.	Offset calibration (sensor input)	
cALG.	Gain calibration (sensor input)	
rEG.	Control action (heat, cool)	
Pb.	Proportional band	
t _i	Integral time (0 excludes integral)	
t _d	Derivative time (0 excludes derivative)	
t _c	Cycle duration for time proportioning output	
tA	Range of amperometric transformator	
ALtA	Operating treshold for T.A.	
AL 1	Select alarm 1	
AL 1	Operating treshold for 1	
R1cr.	Relay contact – alarm 1	
AL 2	Select alarm 2	
R2cr.	Relay contact – alarm 2	
PSE2	Protection set2	
tunE	Select type of autotuning	
SEr.	Select serial or digital input	
Addr.	Slave address	
r it.	Modbus delay	
t _{INE}	Activate timer for delayed start	
SoFt	Soft start	
GrAd.	Select degrees (°C/F)	
cont.	Retransmission for linear output	

15 - INTRODUZIONE

Grazie per aver scelto un regolatore Pixsys.

Il modello ATR400 integra funzioni di comando e controllo, sviluppate per l'automazione di processo, ed è predisposto (in tutte le versioni) per il controllo con seriale RS485 e protocollo Modbus. Tutte le versioni mantengono la completa configurabilità sugli ingressi tipica della strumentazione Pixsys, e una parametrizzazione particolarmente curata consente l'utilizzo di allarmi e uscita continua in differenti soluzioni. Per semplificare la configurabilità in serie dello strumento sono previste **Memory-card** che all'accensione consentono di duplicare in pochi istanti tutti i parametri impostati, o di salvarli per uno storico sul materiale installato.

La protezione sul frontale è IP54 garantita da guarnizioni e da una vite di fissaggio per l'estrazione dell'elettronica.

16 - IDENTIFICAZIONE DEL MODELLO

La famiglia di regolatori ATR400 prevede varie versioni, facendo riferimento alla tabella seguente è facile risalire al modello desiderato.

Composizione della sigla

ATR400-	<input type="checkbox"/>	<input type="checkbox"/>	<input type="checkbox"/>	
Ingressi	1			1 Ingresso TC-RTD-V/I + TA 50mA
Uscite	1			2 uscite relè + 1 uscita 0...10V/4...20mA
	2			3 uscite relè (Out3 in parallelo con SSR)
Alimentazione		AD		12/24V AC $\pm 15\%$ 50/60Hz (con jumper di selezione interno)
		BC		230/115V AC $\pm 15\%$ 50/60Hz (con jumper di selezione interno)

17 - DATI TECNICI	
17.1 - Caratteristiche generali	
Visualizzatori	2 display da 4 digits 0,56 pollici
Temperatura di esercizio	0-45°C, umidità 35..95uR%
Protezione	IP54 Frontale
Materiale	ABS UL94V0 autoestinguente
Peso	450g

17.2 - Caratteristiche hardware	
Ingressi analogici	<p>1: AN1, Configurabile via software Ingresso n.1 Termocoppie tipo K, S, R, J Termoresistenze PT100, Ni100 Ingresso V/I 0-10V, 0-20mA, 4-20mA</p> <p>Tolleranza (25°C) 0.2% ± 1 digit per ingresso a termocoppia, termoresistenza, e V/I. Precisione giunto freddo 0.1°C/°C</p>
Uscite relè	<p>2/3 relè: OUT1, OUT2, OUT3 Configurabili come uscite comando e allarme.</p> <p>Contatti da 8A-250V~ (carico resistivo)</p>
Uscita continua	<p>1 uscita continua Configurabili come uscita comando o ritrasmissione setpoint / processo.</p> <p>Configurabile come 0...10V oppure 4...20mA</p>
Comunicazione seriale	1: RS485 con protocollo modbus.
Ingresso TA	1: Trasformatore amperometrico 50mA Corrente configurabile con soglia d'intervento.
Ingressi digitali	1: IN1 Configurabile come ingresso di blocco o cambio Setpoint 1/2

17.3 - Principali caratteristiche software

Algoritmi regolazione	ON-OFF con isteresi. P, PI, PID, PD a tempo proporzionale
Banda proporzionale	0...9999 °C o °F o "unità di misura"
Tempo integrale	0...9999 sec (0 esclude azione integrale)
Tempo derivativo	0,0...999,9 sec (0 esclude azione derivativa)
Funzioni del regolatore	Tuning manuale o automatico, loop break alarm (allarme rottura carico), allarmi selezionabili, protezione Set2, tempo attesa inizio regolazione.

18 - DIMENSIONI E INSTALLAZIONE

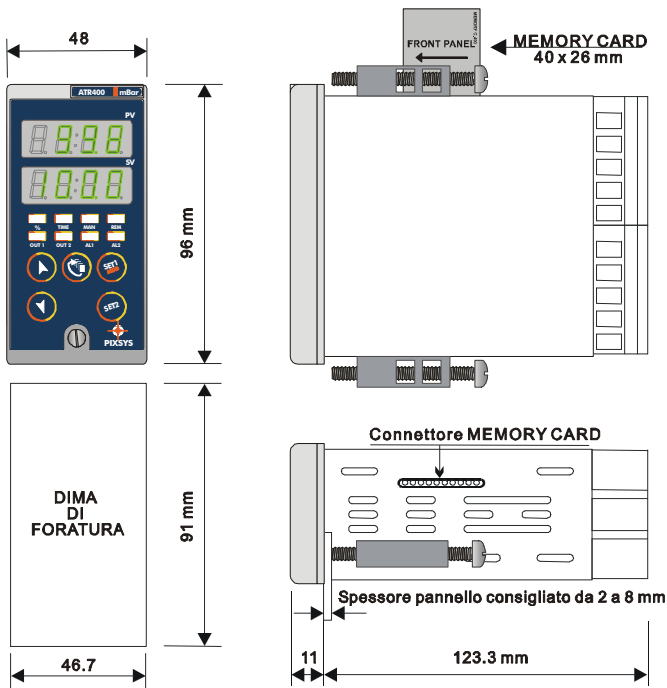

19 - COLLEGAMENTI ELETTRICI



Benché questo regolatore sia stato progettato per resistere ai più gravosi disturbi presenti in ambienti industriali è buona norma seguire la seguenti precauzioni:

- Distinguere la linea di alimentazioni da quelle di potenza.
- Evitare la vicinanza di gruppi di tele ruttori, contattori elettromagnetici, motori di grossa potenza.
- Evitare la vicinanza di gruppi di potenza in particolare se a controllo di fase.

19.1 - Schema di collegamento

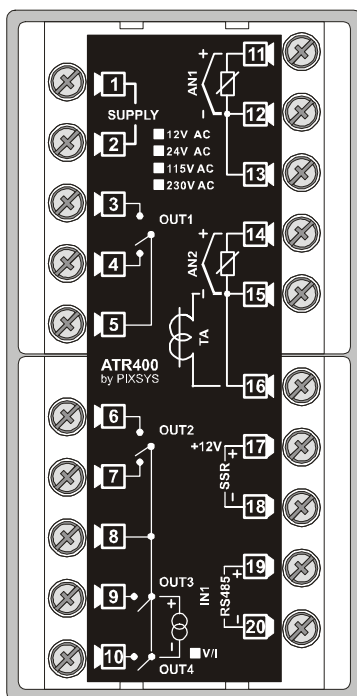

Alimentazione

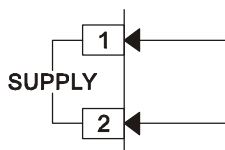

- 12/24Vac $\pm 15\%$ 50/60Hz (selezione da Jumper interno)
- 230/115Vac $\pm 15\%$ 50/60Hz (selezione da Jumper interno)

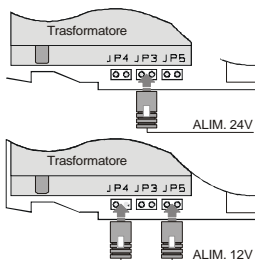

Versione ATR400-xxAD

- Selezionare JP4 e JP5 per **12V AC**
- Selezionare JP3 per **24V AC**

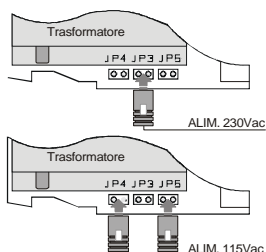

Versione ATR400-xxBC

- Selezionare JP4 e JP5 per **115V AC**
- Selezionare JP3 per **230V AC**

Ingresso analogico

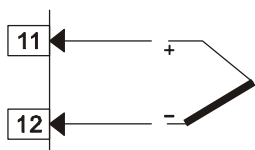

Per termocoppie K, S, R, J

- Rispettare la polarità
- Per eventuali prolunghe utilizzare cavo compensato e morsetti adatti alla termocoppia utilizzata

	<p>Per termoresistenze PT100, NI100</p> <ul style="list-style-type: none"> • Per il collegamento con sonde a tre fili usare cavi della stessa sezione • Per collegamento con sonde a due fili cortocircuitare morsetti 12 e 13.
	<p>Per segnali normalizzati in corrente e tensione</p> <ul style="list-style-type: none"> • Rispettare la polarità
<p>SENSORE DI PRESSIONE</p>	<p>Per segnali normalizzati in corrente 0/4....20mA con sensore a tre fili</p> <p>Rispettare le polarità A=Uscita sensore B=Massa sensore C=Alimentazione sensore</p>
<p>SENSORE DI PRESSIONE</p>	<p>Per segnali normalizzati in corrente 0/4..20mA con sensore ad alimentazione esterna</p> <p>Rispettare le polarità A=Uscita sensore B=Massa sensore</p>
<p>SENSORE DI PRESSIONE</p>	<p>Per segnali normalizzati in corrente 0/4....20mA con sensore a due fili</p> <p>Rispettare le polarità A=Uscita sensore C=Alimentazione sensore</p>

Ingresso seriale

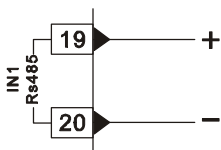

- Comunicazione RS485 Modbus
- Ingresso digitale di blocco configurabile dal parametro 22 **Ser.** come n.o. e n.c.

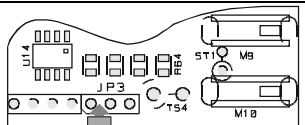

Selezione Seriale MODBUS

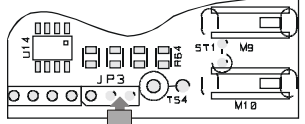

Selezione INGRESSO DIGITALE

- Configurare il jumper JP3 come in figura per selezionare seriale o ingresso digitale

Ingresso TA

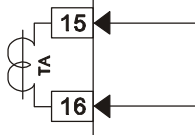

- Ingresso per trasformatore amperometrico da 50mA
- Tempo di campionamento 100ms
- Configurabile da parametri

Uscita continua

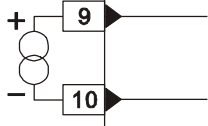

- Uscita continua configurabile da parametri e jumper come 0...10V / 2...10V o 4...20mA (Optoisolata)

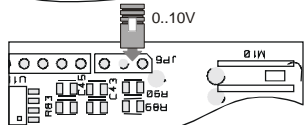
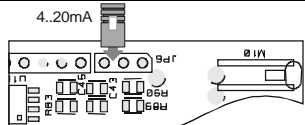



- Configurare il jumper JP6 come in figura per selezionare 0...10V / 2...10V o 4...20mA

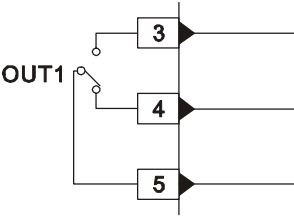
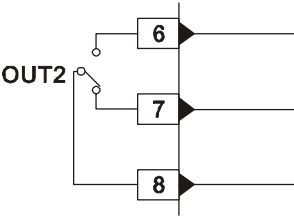
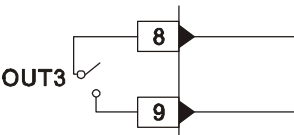
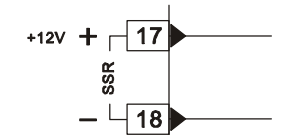



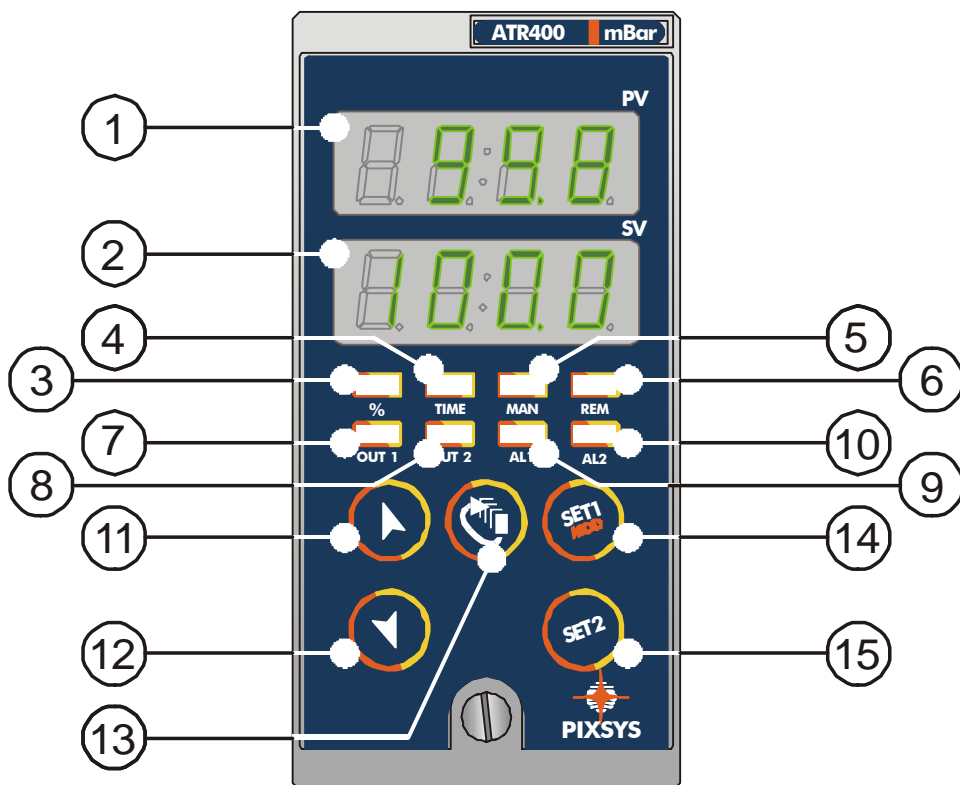



Uscite relè e SSR (configurate da parametro 1)

 <p>OUT1</p>	<p>Portata contatti 8A/250V~ per carichi resistivi</p> <ul style="list-style-type: none"> • Relè di comando con parametro 1 <input type="text" value="cout"/> configurato <input type="text" value="out 1"/> • Relè Apri con configurazione servovalvola apri – chiudi <input type="text" value="SERU"/> • Relè allarme 1 con comando <input type="text" value="SSr"/> e uscite continue.
 <p>OUT2</p>	<p>Portata contatti 8A/250V~ per carichi resistivi</p> <ul style="list-style-type: none"> • Relè Chiudi con configurazione servovalvola apri-chiudi <input type="text" value="SERU"/> • Relè allarme 2 con comando <input type="text" value="out 1"/>, <input type="text" value="SSr"/> e uscite continue.
 <p>OUT3</p> <p>Solo su versione ATR 400-12xx Funziona in parallelo ad uscita SSR</p>	<p>Portata contatti 8A/250V~ per carichi resistivi.</p> <p>Funziona come:</p> <ul style="list-style-type: none"> • Uscita comando con configurazione <input type="text" value="SSr"/> • Allarme 1 con comando <input type="text" value="out 1"/> • Allarme 2 con configurazione servo apri-chiudi <input type="text" value="SERU"/> o comando uscita continua
 <p>+12V +</p> <p>-</p> <p>SSR</p>	<p>COMANDO 12V/30MA</p> <p>Funziona come:</p> <ul style="list-style-type: none"> • Uscita comando con configurazione <input type="text" value="SSr"/> • Allarme 1 con comando <input type="text" value="out 1"/> • Allarme 2 con configurazione servo apri-chiudi <input type="text" value="SERU"/> e comando uscita continua











20 - FUNZIONE DEI VISUALIZZATORI E TASTI



20.1 - Indicatori numerici (display)		
1		Normalmente visualizza il processo (la grandezza rilevata dal sensore in ingresso). In fase di configurazione visualizza il codice del parametro che si sta inserendo. Visualizza il valore di corrente assorbita con la funzione "Loop Break alarm" abilitata.
2		Visualizza i setpoint, la percentuale di uscita, la selezione automatico/manuale. In fase di configurazione visualizza il valore del parametro che si sta inserendo.

20.2 - Significato delle spie di stato (led)		
3		Lampeggia quando indica la percentuale dell'uscita in funzionamento P.I.D.
4		Lampeggia in fase di programmazione del tempo di attesa. Acceso durante l'attesa.
5		Lampeggia durante la programmazione auto/man. Acceso in funzionamento manuale.
6		Si accende quando il regolatore risponde ad un'interrogazione della seriale.
7		Si accende quando l'uscita di comando è attiva. In caso di servo apri-chiudi si accende quando la valvola si sta aprendo.
8		Si accende quando in funzionamento servo apri-chiudi la valvola si sta chiudendo.
9		Si accende quando l'allarme 1 è attivo.
10		Si accende quando l'allarme 2 è attivo.











20.3 - Tasti

11		<ul style="list-style-type: none">• Modifica i setpoint quando premuto in seguito ed insieme al tasto  oppure al tasto .• In fase di configurazione consente di scorrere i parametri. Con il tasto  li modifica.• Modifica la percentuale dell'uscita in funzionamento manuale.• Seleziona il funzionamento automatico/manuale.• Modifica il valore del timer.
12		<ul style="list-style-type: none">• Modifica i setpoint quando premuto in seguito ed insieme al tasto  oppure al tasto .• In fase di configurazione consente di scorrere i parametri. Con il tasto  li modifica.• Modifica la percentuale dell'uscita in funzionamento manuale.• Seleziona il funzionamento automatico/manuale.• Modifica il valore del timer.
13		<ul style="list-style-type: none">• Permette di accedere e uscire dalla configurazione parametri.• Scorre le varie funzioni del regolatore: visualizza la percentuale dell'uscita comando, seleziona il funzionamento manuale/automatico, imposta il timer se configurato.
14		<ul style="list-style-type: none">• Permette di variare il setpoint 1.• Permette di variare i parametri di configurazione.
15		<ul style="list-style-type: none">• Permette di visualizzare / variare il setpoint 2.

21 - FUNZIONI DEL REGOLATORE

21.1 - Regolazione automatico/manuale

Questa modalità seleziona la percentuale dell'uscita comando manualmente, oppure nel funzionamento automatico in base ai parametri di processo.

	Premere	Effetto	Eeguire
1		Questo tasto, in modo ciclico, permette di visualizzare sul display 2 percentuale di uscita, tempo attesa (se abilitato), selezione auto/man e setpoint.	Premere  fino al lampeggio del led  .
2	 	Si modifica la scritta  oppure  .	
3		Premere finché non lampeggia il led  . Il display 2 visualizza la percentuale dell'uscita.	Premendo   modifica la percentuale dell'uscita (regolatore in manuale).

21.2 - Loop Break Alarm

Permette di misurare la corrente sul carico per gestire un allarme in caso di malfunzionamento con stadio di potenza in corto oppure sempre aperto. Il trasformatore amperometrico collegato ai morsetti 15 e 16 deve essere da 50mA (tempo di campionamento 100ms).



- Impostare sul parametro 13 **EA** il valore in ampere del trasformatore amperometrico.
- Impostare sul parametro 14 **ALFA** la soglia di intervento del Loop Break Alarm.
- E' possibile azionare un relè, impostando sul parametro 15 **AL. 1** o 18 **AL. 2**, la selezione **ALFA**.

Nel caso un teleruttore o relè allo stato solido dovesse restare sempre chiuso il regolatore segnala il guasto visualizzando **brtc**.

Nel caso invece lo stadio di potenza dovesse restare sempre aperto il regolatore visualizza **brto**.

Lo stato di allarme cessa se scompare l'anomalia.

E' possibile visualizzare la corrente assorbita in fase di chiusura dello stadio di potenza.



	Premere	Effetto	Eeguire
1		Questo tasto, in modo ciclico, permette di visualizzare sul display 2 percentuale di uscita, tempo attesa (se abilitato), selezione auto/man e setpoint.	Premere  fino al lampeggio del led  . Il display 1 visualizza la corrente (se la funzione L.B.A. è attiva) mantenendo il valore anche quando non c'è corrente sul carico.

21.3 - Auto-tune

La procedura di Auto-tune⁽¹⁾ per il calcolo dei parametri di regolazione, può essere lanciata manualmente, o in maniera automatica ad ogni accensione dello strumento o al cambio del Setpoint di regolazione.

21.4 - Tuning manuale

Il tuning manuale (abilitato dal parametro 21 `TUNE`) può essere lanciato solo quando il regolatore visualizza processo e setpoint, e per sicurezza sugli over-shot (sovratemperatura) con il processo inferiore di almeno il **35%** sul valore di setpoint.



	Premere	Effetto	Eeguire
1	Premere prima  e poi  .	Il display 2 visualizza alternativamente il setpoint e la scritta <code>TUNE</code> .	Attendere fino a che sul display 2 scompare la scritta <code>TUNE</code> . Se si desidera terminare la procedura anticipatamente, premere  .

21.5 - Tuning automatico

Il tuning automatico (abilitato dal parametro 21 `TUNE`) si attiva all'accensione dello strumento o quando viene modificato il setpoint di almeno un 35%. Il display 2 visualizza alternativamente il setpoint e la scritta `TUNE`. E' possibile uscire dal tuning lasciando invariati i valori P.I.D. premendo .

(2) L'accesso a tale procedura da parte dell'utente può essere disabilitato dall'installatore (vedi cap. 23, Parametro-21).

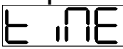
21.6 - Attesa inizio regolazione

Questa funzione permette di impostare un tempo di attesa prima che il regolatore cominci a lavorare. Il parametro 25  abilita la funzione. All'accensione è acceso il led  (se un tempo è impostato) indicando l'attesa.

	Premere	Effetto	Eeguire
1		Questo tasto, in modo ciclico, permette di visualizzare sul display 2 percentuale di uscita, tempo attesa (se abilitato), selezione auto/man e setpoint.	Premere  fino al lampeggio del led  .
2	 	Modifica il tempo di attesa iniziale visualizzato sul display 2.	Durante l'attesa  il regolatore esce dalla funzione. Spegnere e riaccendere per riattivare l'attesa.

21.7 - Soft Start

Il regolatore all'accensione, per raggiungere il setpoint, segue un gradiente di salita impostato in gradi/ora.

Impostare sul parametro 26 **SOFT** il valore desiderato; alla successiva accensione lo strumento eseguirà la funzione Soft Start.

Se è abilitata la funzione Tuning automatico il Soft Start viene automaticamente disabilitato. Se viene lanciata la funzione di Tuning manuale, mentre il regolatore sta eseguendo il Soft Start, quest'ultimo viene interrotto.

21.8 - Memory Card

E' possibile duplicare parametri, setpoint e tempo attesa da un regolatore ad un altro mediante l'uso della Memory Card. Inserire la Memory Card **con regolatore spento** facendo **attenzione al verso di inserimento**. Accendendo il controller il display 1 visualizza **no** e il display 2 visualizza **no**¹.

	Premere	Effetto	Eeguire
1		 visualizza YES ,  visualizza no .	Selezionare YES se si desidera caricare i valori contenuti nella Memory Card all'interno del regolatore, altrimenti selezionando no i valori rimarranno invariati.
3		Il regolatore carica i valori e il cicalino avvisa dell'avvenuto trasferimento; il regolatore riparte.	

¹ Solo se nella Memory Card sono salvati valori corretti.

Aggiornamento dei valori della Memory Card.

Per *aggiornare* i valori della Memory Card, seguire il procedimento appena descritto impostando  sul display 2 in modo da non caricare i valori della Memory Card sul regolatore². Entrare in configurazione e **variare almeno uno dei parametri**. Uscendo dalla configurazione, un suono del cicalino segnalerà il salvataggio dei nuovi valori sulla Memory.



22 - CONFIGURAZIONE

22.1 - Modifica parametro di configurazione

Per modificare i parametri di configurazione (vedi cap. 9) è necessario che il regolatore sia in visualizzazione con indicazione del processo e del Setpoint.

	Premere	Effetto	Eeguire
1	 Tenere premuto per 5 sec.	Su display 1 compare  con la 1° cifra lampeggiante, mentre sul display 2 compare 	
2	  e 	Si modifica la cifra lampeggiante e si passa alla successiva.	Inserire la password 
3		Su display 1 compare il primo parametro e sul secondo il suo valore.	

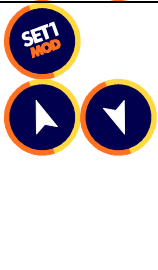
² Nel caso in cui all'accensione il regolatore non visualizzi  significa che non ci sono dati salvati nella Memory Card, ma è possibile ugualmente aggiornarne i valori.

4		Scorre i parametri	
5		<p>Si incrementa o decrementa il valore visualizzato premendo prima</p>  <p>e poi un tasto freccia.</p>	<p>Inserire il nuovo valore. Per variare un altro parametro tornare al punto 4</p>
6		<p>Fine variazione parametri di configurazione. Il regolatore esce dalla programmazione.</p>	



23 - TABELLA PARAMETRI DI CONFIGURAZIONE

N.	Display	Descrizione parametro	Range di inserimento
1	c.out	<p>Definisce la funzionalità delle uscite sul regolatore.</p> <p>Le opzioni disponibili sul display 2 identificano il tipo di uscita comando per il controllo del sistema.</p> <p>Ognuna di queste selezioni definisce inoltre le uscite secondarie disponibili come allarme (configurabili nei parametri dal15 al 19).</p> <p>(Nel caso di uscita comando 0..10,2..10, 4..20 estrarre il regolatore dal frontale, identificare il jumper JP6 e posizionarlo in maniera corretta come indicato a pag.38)</p>	<p>out 1 : out1 comando SSR* allarme1 out 2 allarme 2</p> <p>SSr : SSR* comando out1 allarme 1 out2 allarme 2</p> <p>SErU : out1(Apri)+out2(Chiudi) comando valvola SSR* allarme 2</p> <p>c.0.10 : comando 0..10V out1=allarme 1 out2+SSR* = allarme 2</p> <p>c.2.10 : comando 2..10V out1= allarme 1 out2+SSR* = allarme 2</p> <p>c.420 : comando 4..20mA out1= allarme 1 out2+SSR* =allarme 2</p> <p>N.B.: Può essere selezionato c.0.10, c.2.10 e c.420 solo nella versione con uscita continua ATR400-11XX</p>

* SSR funziona insieme ad Out3 nella versione ATR400-12XX.

N.	Display	Descrizione parametro	Range di inserimento
2	SEn	Configurazione ingresso analogico	Ec. T : (-260°...1360°C) Termocoppia tipo K Ec. S : (-40°...1760°C) Termocoppia tipo S Ec. r : (-40°...1760°C) Termocoppia tipo R Ec. U : (-200°...1200°C) Termocoppia tipo J PE : (-50°...800°C) PT100 PE I : (-50.0°...800.0°C) PT100 (con decimale) n I : (-50°...200°C) NI100 n I I : (-50.0°...200.0°C) NI100 (con decimale) 0.10 : 0...10V senza decimo 020 : 0...20mA senza decimo 420 : 4...20mA senza decimo 0.10.1 : 0...10V un decimo 020.1 : 0...20mA un decimo 420.1 : 4...20mA un decimo
3	inF.	Limite inferiore della scala	-999...+9999 digit o -99.9...+999.9 digit
4	Sup.	Limite superiore della scala	-999...+9999 digit o -99.9...+999.9 digit

N.	Display	Descrizione parametro	Range di inserimento
5	HYS.	Isteresi (Ritardo sull'abilitazione dell'uscita Comando)	-999...+999 digit
6	cALo.	Calibrazione offset (Valore fisso da aggiungere o sottrarre alla visualizzazione della sonda)	-150...+150 unità
7	cALG.	Calibrazione guadagno (Variazione della pendenza della linearizzazione)	-10.0%...+10.0%
8	rEG.	Tipo regolazione	cold : freddo (n.c.) Hot : caldo (n.a.)
9	Pb.	Banda proporzionale. Inerzia del processo in unità (Esempio: se temperatura in °C)	0 on/off 1-9999 digit
10	t. i.	Tempo integrale. Inerzia del processo in secondi.	0-9999 secondi (0 integrale disabilitato)
11	t.d.	Tempo derivativo. Normalmente ¼ del tempo integrale.	0.0-999.9 secondi (0 derivativo disabilitato)
12	t.c.	Tempo ciclo (per PID su teleruttore 10/15sec, per PID su SSR 1 sec) o tempo servo (valore dichiarato da produttore del servomotore).	1-120 secondi
13	tA.	Abilitazione e range di fondoscala del trasformatore amperometrico	0 T.A disabilitato 1-200 Ampere

14	ALTA	Soglia di intervento T.A.	0-200 Ampere
15	AL. 1	Selezione allarme 1	<p>ALR : assoluto riferito al processo (di soglia)</p> <p>ALB : banda (es. mettendo il set a 5°C, l'uscita si attiva 5° oltre e 5° prima del valore del set principale).</p> <p>ALDS : deviazione superiore (es. mettendo il set a 5°C, l'uscita si attiva 5° oltre il valore del set principale).</p> <p>ALDI : deviazione inferiore (es. mettendo il set a 5°C, l'uscita si attiva 5° prima del valore del set principale).</p> <p>ALAS : assoluto riferito al setpoint 1</p> <p>ALTA : Loop Break Alarm</p>
16	AL. 1	<p>Per la regolazione e l'eventuale allarme2 sono disponibili i tasti</p> <p> e , mentre per la modifica nel caso dell'allarme1, è questo parametro che definisce il valore di set, non modificabile quindi al di fuori della config.</p>	<p>-999...+9999 digit</p> <p>-99.9...+999.9 digit</p>

N.	Display	Descrizione parametro	Range di inserimento
17	A.lcr.	Contatto relè allarme 1	no. : Relè norm. aperto nc. : Relè norm. chiuso
18	AL. 2	Selezione allarme 2 L'intervento dell'allarme2 è identificato dal SET2.	ALA : assoluto riferito al processo (di soglia) ALb. : banda ALdS. : deviazione superiore ALd. i. : deviazione inferiore ALAS. : assoluto riferito al setpoint 1 ALBA. : Loop Break Alarm
19	A2cr.	Contatto Relè allarme 2	no. : Relè norm. aperto nc. : Relè norm. chiuso
20	PSE2	Protezione set2	FrEE : modifica del set 2 abilitata fuori dalla configurazione Prot. : modifica del set 2 disabilitata
21	tunE	Selezione tipo autotuning	oFF :disabilitato Auto :sempre attivo NAn. :lanciato da tastiera

N.	Display	Descrizione parametro	Range di inserimento
22	SEr.	Selezione ingresso seriale o digitale. Selezionare jumper JP3 come da figura a pagina 39.	<p>ndb.1 : baud rate 38400</p> <p>ndb.2 : baud rate 19200</p> <p>ndb.3 : baud rate 9600</p> <p>ndb.4 : baud rate 4800</p> <p>b. vna : quando ingresso attivo (n.o.) viene inibita uscita di regolazione (Comando)</p> <p>b. vnc : quando ingresso attivo (n.c.) viene inibita uscita di regolazione (Comando)</p> <p>SSna : quando ingresso attivo (n.o.) cambia Setpoint di comando/regolazione (da Set1 a Set2)</p> <p>SSnc : quando ingresso attivo (n.c.) cambia Setpoint di comando/regolazione (da Set1 a Set2)</p>
23	Addr.	Indirizzo slave	1-99
24	r it.	Ritardo modbus	0-250 ms
25	t iNE	Abilita timer. Funzione attesa iniziale	<p>oFF :timer disabilitato</p> <p>UR it :timer abilitato</p>

26	SoFt	Soft start (Versione 2.0)	0 disabilitato 1-1000 gradi/ora
27	GrAd.	Selezione tipo gradi	0C : gradi centigradi 0F : gradi fahrenheit

N.	Display	Descrizione parametro	Range di inserimento
28	cont.	Ritrasmissione per uscita continua. (Jumper JP6 per uscita continua) I parametri 3 e 4 definiscono il limite inferiore e superiore della scala di funzionamento N.B. L'uscita continua in modalità ritrasmissione risulta non disponibile nel caso il parametro SEn sia utilizzato come uscita comando/regolazione	oFF : disabilitata 0.10S : ritrasm. Set1 420S : ritrasm. Set1 0.10A : ritrasm. Set2 420A : ritrasm. Set2 0.10P : ritrasm. Proc. 420P : ritrasm. Proc.

Intervento di banda (setpoint-processo)

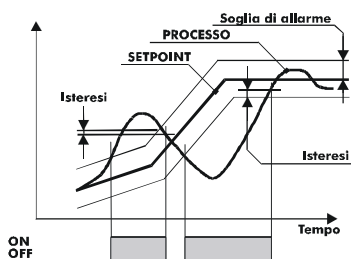

L'allarme può essere:

- Attivo fuori
- Attivo entro

Nell'esempio in figura è attivo fuori.

Intervento di deviazione (setpoint-processo)

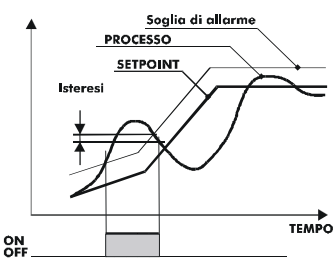

L'allarme può essere:

- di deviazione superiore
- di deviazione inferiore

Nell'esempio è deviazione superiore.

Intervento indipendente (processo)

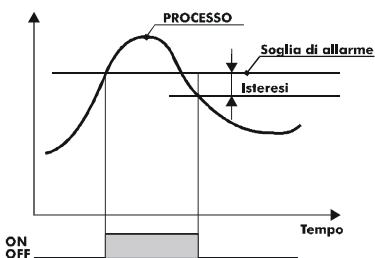

L'allarme può essere:

- Attivo sopra
- Attivo sotto

Nell'esempio in figura è attivo sopra.

25 - PROTOCOLLO DI COMUNICAZIONE MODBUS RTU

25.1 - Caratteristiche

L'ATR400 è stato sviluppato per l'utilizzo e il controllo tramite terminali con protocollo Modbus. La seriale permette la programmazione dei parametri di configurazione, degli ingressi e delle uscite, e la lettura dell'ingresso sonda.

L'ATR400 dispone di una seriale di comunicazione RS485.

Baud-rate	Selezionabile da parametri 38400 bits/sec 19200 bits/sec 9600 bits/sec 4800 bits/sec
Formato	8, N, 1(8bit, no parità, 1 stop)
Funzioni supportate	WORD READING (max 1 word) (0x03, 0x04) SINGLE WORD WRITING (0x06)

N.B.

Per ulteriori dettagli sulla comunicazione seriale richiedere la nota applicativa n° AN-0014-xxxx.

25.2 - Indirizzi word ATR400

MODBUS ADDRESS	DESCRIZIONE	READ/WRITE	RESET VALUE ²
1	Processo	R	?
2	Temperatura giunto freddo	R	?
3	Setpoint 1	R/W	EEP
4	Setpoint 2	R/W	EEP
5	Valore uscita proporzionale	R/W	?
6	Selezione automatico/manuale	R/W	EEP
7	Tempo attesa iniziale	R/W	EEP
8	Corrente T.A.	R	0
9	Parametro 1 <input type="text" value="cout"/>	R/W	EEP
10	Parametro 2 <input type="text" value="SEn"/>	R/W	EEP
11	Parametro 3 <input type="text" value="inF."/>	R/W	EEP
12	Parametro 4 <input type="text" value="SuP."/>	R/W	EEP
13	Parametro 5 <input type="text" value="HYS."/>	R/W	EEP
14	Parametro 6 <input type="text" value="cALD."/>	R/W	EEP
15	Parametro 7 <input type="text" value="cALD."/>	R/W	EEP
16	Parametro 8 <input type="text" value="rEG."/>	R/W	EEP
17	Parametro 9 <input type="text" value="Pb."/>	R/W	EEP
18	Parametro 10 <input type="text" value="t.i."/>	R/W	EEP
19	Parametro 11 <input type="text" value="td."/>	R/W	EEP
20	Parametro 12 <input type="text" value="tc."/>	R/W	EEP
21	Parametro 13 <input type="text" value="tR."/>	R/W	EEP

² In base al valore di inizializzazione all'accensione, si distinguono i seguenti casi:

3. "EEP" Valore memorizzato in memoria Eeprom.
4. "?" Valori sconosciuti all'accensione.

MODBUS ADDRESS	DESCRIZIONE	READ/WRITE	RESET VALUE
22	Parametro 14 ALTA	R/W	EEP
23	Parametro 15 AL. 1	R/W	EEP
24	Parametro 16 AL. 1	R/W	EEP
25	Parametro 17 A1cr.	R/W	EEP
26	Parametro 18 AL. 2	R/W	EEP
27	Parametro 19 A2cr.	R/W	EEP
28	Parametro 20 PSE2	R/W	EEP
29	Parametro 21 tunc	R/W	EEP
30	Parametro 22 SEr.	R/W	EEP
31	Parametro 23 Addr.	R/W	EEP
32	Parametro 24 r it.	R/W	EEP
33	Parametro 25 t inE	R/W	EEP
34	Parametro 26 SOFT	R/W	EEP
35	Parametro 27 CrAd.	R/W	EEP
36	Parametro 28 cont.	R/W	EEP
37	Abilitazione regolazione	R/W	0
50	Byte Display1 (4° digit)	R	EEP
51	Byte Display1 (3° digit)	R	EEP
52	Byte Display1 (2° digit)	R	EEP
53	Byte Display1 (1° digit)	R	EEP
54	Byte Display2 (4° digit)	R	EEP
55	Byte Display2 (3° digit)	R	EEP
56	Byte Display2 (2° digit)	R	EEP
57	Byte Display2 (1° digit)	R	EEP
58	Byte Led	R	EEP
59	Byte Tasti	W	EEP

26 - TABELLA SEGNALAZIONI ANOMALIE

In caso di mal funzionamento dell'impianto il controllore spegne l'uscita di regolazione e segnala il tipo di anomalia riscontrata. Per esempio il regolatore segnalerà la rottura di un'eventuale termocoppia collegata visualizzando **E-05** (lampeggiante) sul display. Per le altre segnalazioni vedi la tabella sottostante.

#	Causa	Cosa Fare
E-01	Errore in programmazione cella E ² PROM.	-
E-02	Guasto sensore temperatura giunto freddo o temperatura ambiente al di fuori dei limiti ammessi.	-
E-04	Dati di configurazione errati. Possibile perdita della tarature dello strumento.	Verificare che i parametri di configurazione siano corretti.
E-05	Termocoppia aperta o temperatura fuori limite.	Controllare il collegamento con le sonde e la loro integrità.
6-00	Loop break alarm. Corrente non presente sul carico.	Verificare funzionamento stadio di potenza(teleruttori, relè allo stato solido...).
6-02	Loop break alarm. Corrente sempre presente sul carico.	Verificare funzionamento stadio di potenza(teleruttori, relè allo stato solido...).

27 - PROMEMORIA CONFIGURAZIONE**Data:****Modello ATR400:**

Note:

cout	Selezione tipo uscita di comando	
SEn	Configurazione ingresso analogico AN1	
inf.	Limite inferiore della scala	
SuP.	Limite superiore della scala	
HYS	Isteresi della soglia di intervento delle uscite	
cALo.	Calibrazione offset ingresso sensore	
cALG.	Calibrazione guadagno ingresso sensore	
rEG.	Tipo regolazione (caldo, freddo)	
Pb.	Banda proporzionale	
t _i	Tempo integrale. (0 integrale escluso)	
t _d	Tempo derivativo. (0 derivativo escluso)	
t _c	Durata ciclo per uscita a tempo proporzionale	
tA	Range del trasformatore amperometrico	
ALtA	Soglia di intervento del T.A.	
AL. 1	Selezione allarme 1	
AL. 1	Soglia di intervento allarme 1	
A1cr.	Contatto relè allarme 1	
AL. 2	Selezione allarme 2	
A2cr.	Contatto relè allarme 2	
PSE2	Protezione set2	
tune	Selezione tipo autotuning	
SEr.	Selezione ingresso seriale o digitale	
Addr.	Indirizzo slave	
r it.	Ritardo modbus	
t _{INE}	Abilitazione timer attesa regolazione	
Soft	Soft start	
GrAd.	Selezione tipo gradi	
cont.	Funzioni di ritrasmissione per uscita continua	

Note

Software Rev.2.20

2300.10.011-RevB 270204



TRAFAG ITALIA S.r.l.
c/o Tecnocity Altomilanese
Via Cremona 1
20025 Legnano (MI)

Tel: 0331 592 397
Fax: 0331 599 815
www.trafagititalia.com
info@trafagititalia.com



Cap. Soc. 41600,00 EURO i.v., CCIAA 11819540151 R.E.A. 1502506, P.IVA 11819540151