



REGOLATORE CONTROLLER

ATR-110

ATR-120

ATR-140

Manuale

User Manual

1 SEZIONE UTENTE	3	20 SECTION FOR THE USER	31
2 VISUALIZZATORI E TASTI	3	21 DISPLAYS AND KEYS	31
3 CAMBIO DEL SETPOINT (TEMPERATURA IMPOSTATA)	4	22 CHANGE OF SETPOINT VALUE	32
4 SEGNALAZIONE ANOMALIE	5	23 LIST OF ANOMALY SIGNS	33
5 SEZIONE INSTALLATORE	6	24 SECTION FOR THE INSTALLER	34
6 INTRODUZIONE	6	25 INTRODUCTION	34
7 COMPOSIZIONE DELLA SIGLA	6	26 ORDERING CODE	34
8 CARATTERISTICHE	9	27 TECHNICAL DATA	37
9 COLLEGAMENTI ELETTRICI	11	28 ELECTRICAL WIRINGS	38
10 SCHEMA DI COLLEGAMENTO ATR110 / ATR120 IN BASSA TENSIONE	12	29 WIRING PLAN ATR110 / ATR120 - LOW VOLTAGE 12..24	39
11 SCHEMA DI COLLEGAMENTO ATR110 / ATR140 ALIMENTAZIONE DA RETE	15	30 WIRING PLAN ATR110 / ATR140 SUPPLY 115/230V	42
12 MODI DI INTERVENTO USCITA ALLARME OUT 2 (SOLO ATR120)	17	31 ALARM OUTPUT OUT 2 (ONLY ATR120)	44
13 MODIFICA PARAMETRI DI CONFIGURAZIONE	18	32 CHANGE OF CONFIGURATION PARAMETERS	45
14 ELENCO PARAMETRI DI CONFIGURAZIONE	19	33 CONFIGURATION PARAMETERS	47
15 TUNING	24	34 TUNING	52
16 TECNICA DI TUNING MANUALE PER ATR110/120 VERS. AD	26	35 MANUAL TUNING FOR ATR110/120 VERSION XX-AD	53
17 LANCIO DEL TUNING (SOLO ATR110 E ATR140 B / C)	26	36 TUNING START (ONLY ATR110 AND ATR140 B / C)	53
18 TECNICA DI TUNING AUTOMATICO	27	37 AUTOMATICAL TUNING	54
19 COMUNICAZIONE SERIALE (SOLO SU MOD. ATR110-12BT -12CT)	28	38 SERIAL COMMUNICATION (ONLY ON ATR110-12BT -12CT)	55

1 SEZIONE UTENTE

2 VISUALIZZATORI E TASTI

Visualizza normalmente il processo (es. Temperatura sonda), ma può visualizzare anche il valore di setpoint (punto d'intervento) oppure i dati in inserimento.

In programmazione

Incrementa

Decrementa

il valore della cifra lampeggiante (con avanzamento veloce).

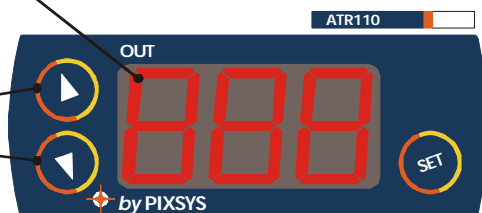

Visualizza il set-point n°2 (temperatura impostata per la seconda soglia). Se premuto contemporaneamente ad uno dei tasti freccia permette di modificarne il valore.

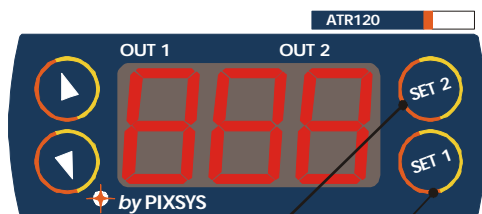



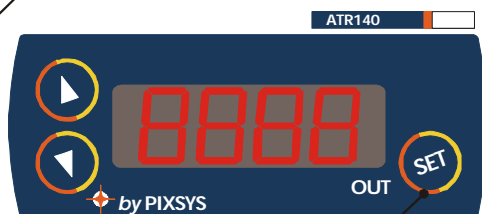





Visualizza il set-point (temperatura impostata per la prima soglia). Se premuto contemporaneamente ad uno dei tasti freccia permette di modificarne il valore.



3 CAMBIO DEL SETPOINT (TEMPERATURA IMPOSTATA)

Per Modificare la temperatura impostata premere il tasto set e contemporaneamente il tasto freccia desiderato, dopo pochi istanti il display si sposterà più velocemente per raggiungere la soglia desiderata.

	Premere	Effetto	Eeguire
1	 o 	Il display visualizza il valore di set-point (1 o 2)	Tenere premuto il tasto per modificare il valore.
2	  +  	Il valore del set-point varia in funzione del tasto premuto.	Premere  o  insieme ad uno dei tasti freccia per aumentare o diminuire il valore di set-point desiderato. Al rilascio dei tasti il nuovo valore viene registrato automaticamente.

4 SEGNALAZIONE ANOMALIE

In caso di mal funzionamento dell'impianto il regolatore blocca l'eventuale ciclo in esecuzione e segnala il tipo di anomalia riscontrata.

Per esempio il regolatore segnalerà la rottura di una eventuale

termocoppia collegata visualizzando **E-5** (lampeggiante) sul display.

Per le altre segnalazioni vedere la tabella sottostante.

Errore	Causa	Cosa fare
E-1	Errore EEPROM / Scrittura	
E-4	Errore programmazione	Verificare o riconfigurare i parametri.
E-5	Termocoppia/termoresistenza aperta o in corto / temperatura fuori range	Verificare la connessione con le sonde e la loro integrità.
E-6	Conversione ADC fuori range	Verificare la connessione con le sonde e la loro integrità.
E-7	Giunto freddo fuori range	Temperatura ambiente probabilmente fuori range

5 SEZIONE INSTALLATORE

6 INTRODUZIONE

Grazie per aver scelto un regolatore Pixsys.

Questa serie di regolatori in formato 32x74 ha la flessibilità di impiego garantita dall'ingresso sonda selezionabile. La gamma prevede modelli con lettura di sonde per temperatura e modelli per lettura di segnali normalizzati. Sono inoltre disponibili versioni per alta temperatura con 4 digit di visualizzazione, adatti a sonde tipo K fino a 1350°C.

Il tipo di regolazione è ON/OFF con isteresi e PI per le versioni a bassa tensione (12/24Volt), mentre è disponibile l'algoritmo di regolazione PID con Autotune sulle versioni con trasformatore interno (115/230Volt).

Seguendo le tabelle sottostante si può facilmente identificare il modello desiderato.

7 COMPOSIZIONE DELLA SIGLA

7.1 Composizione della sigla Modello ATR110 Display 3 cifre, alimentazione in bassa tensione, una soglia e controllo PI.

ATR110-	<input type="checkbox"/>	<input type="checkbox"/>	<input type="checkbox"/>	
Ingressi	1			Termoresistenza PT100, PTC 1000 Ohm, PTC 2000 Ohm Termocoppia (solo modelli ISOLATI) K , J 0/4...20mA 0...1/10Volt
	2			
Uscite	0			Solo visualizzazione
	1			1 SSR (12...24V 50mA)
	2			1 Relè 8A
Alimentazione			AD	12...24V AC/DC $\pm 10\%$ 50/60Hz

7.2 Composizione della sigla Modello ATR120

Display 3 cifre, alimentazione in bassa tensione, due soglie e controllo PI.

ATR120-	<input type="checkbox"/>	<input type="checkbox"/>	<input type="checkbox"/>	
Ingressi	1			Termoresistenza PT100, PTC 1000 Ohm, PTC 2000 Ohm Termocoppia (solo modelli ISOLATI) K , J 0/4...20mA 0...1/10Volt
	2			
Uscite	1			1 SSR (12...24V 50mA) + 1 Relè 8A 2 Relè 8A
	2			
Alimentazione			AD	12...24V AC/DC $\pm 10\%$ 50/60Hz

7.3 Composizione della sigla Modello ATR110

Display 3 cifre, alimentazione da rete, una soglia e controllo PID con Autotune e opzione seriale RS485.

ATR110-1				Ingressi Termocoppia K , J e PT100
Uscite	1			1 SSR (12V 30mA)
	2			1 Relè 8A
Alimentazione		B		230 Vac $\pm 10\%$ 50/60 Hz
			C	115 Vac $\pm 10\%$ 50/60 Hz
Seriale			T	RS485 (ModbusRTU,300Baud)

7.4 Composizione della sigla Modello ATR140

Display 4 cifre, alimentazione da rete, una soglia e controllo PID con Autotune, visualizzazione fino a 1350°C con termocoppia K.

ATR140-1				Ingressi Termocoppia K , J e PT100
Uscite	1			1 SSR (12V 30mA)
	2			1 Relè 8A
Alimentazione		B		230 Vac $\pm 10\%$ 50/60 Hz
			C	115 Vac $\pm 10\%$ 50/60 Hz

8 CARATTERISTICHE

8.1 Caratteristiche generali

Display	3 display ATR110 / 4 display ATR140/ (0,56 pollici) + 2 led
Temperatura di esercizio	0-45°C - umidità 35..95uR%
Protezione	Pannello frontale IP54 / Contenitore IP30 / Morsettiere IP20
Materiale	ABS UL94V0 autoestinguente
Peso	ca. 100 gr.

8.2 Caratteristiche hardware

Ingressi analogici	1 AN1	
	configurabile via software Termocoppie : K,J Termoresistenze: PT100, PTC 1000 ohm / 2000 ohm 0/4..20mA (Ri<=50ohm) 0..10V(Ri>=1Mohm)	Tolleranze (25°C) 0.5 % ± 1 digit x termocoppie e termoresistenze Giunto freddo 0.1°C/°C di temperatura ambiente 0.2% ± 1 digit per V/I
Uscite	1 / 2 Rele' : OUT1, OUT2 (solo ATR120)	
	OUT1 : regolazione OUT2 : allarme configurabile	Contatti da 8A- 250V~ (su carico resistivo)

8.3 Caratteristiche software

Algoritmo di regolazione	On/OFF con isteresi o P.I. ATR110/120-AD On/OFF con isteresi o P.I.D. ATR110/140 B -C
Protezione dati	Parametri sotto password

8.4 Dimensioni e installazione

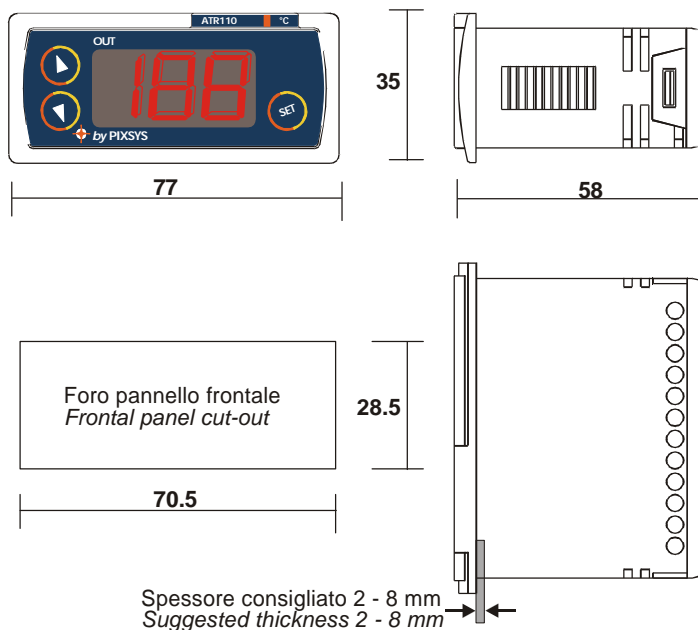

9 COLLEGAMENTI ELETTRICI



Benché questo regolatore sia stato progettato per resistere ai più gravosi disturbi presenti in ambienti industriali, è buona norma seguire le seguenti precauzioni:

Distinguere la linea d'alimentazione da quelle di potenza.

Evitare la vicinanza di gruppi di teleruttori, contattori elettromagnetici, motori di grossa potenza.

Evitare la vicinanza di gruppi di potenza, in particolare se a controllo di fase.

10 SCHEMA DI COLLEGAMENTO ATR110 / ATR120 IN BASSA TENSIONE

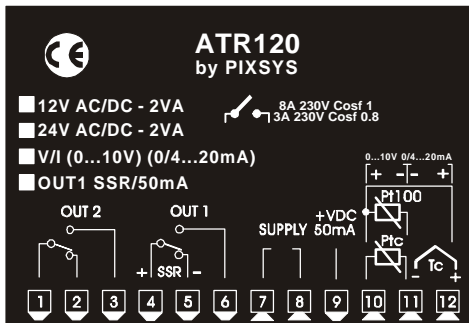
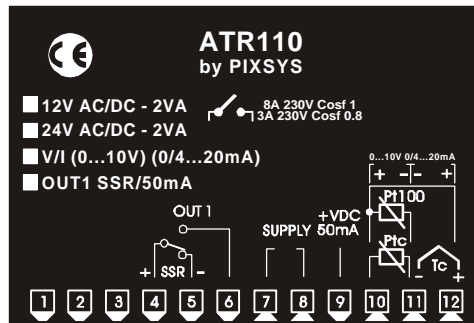

10.1 Alimentazione in bassa tensione 12/24 Vac-Vdc Modelli: ATR110-xxAD e ATR120-xxAD

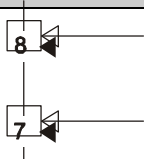

12Vac...24Vac +/- 10% 50Hz/60Hz

10.2 Ingresso analogico per sonde in temperatura Modelli: ATR110-1xAD, ATR120-1xAD

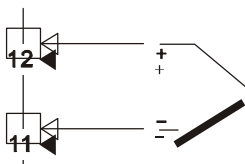

Per termocoppia K, J;
Rispettare le polarità
Per eventuali prolunghe utilizzare cavo compensato adatto alla termocoppia utilizzata
ATTENZIONE (solo per modelli -1xAD)
Per un corretto funzionamento dello strumento, utilizzare sonde isolate da terra.
In caso contrario, utilizzare singolo trasformatore isolato per ogni strumento.

	<p>Per termoresistenza Pt100 a tre fili, Per il collegamento a tre fili usare cavi della stessa sezione. Per Pt100 a due fili cortocircuitare morsetti 10 e 12.</p> <p>Attenzione. I due fili A e C essendo in parallelo solitamente sono dello stesso colore.</p>
	<p>Per PTC mod. KTY 1000 Ohm mod. KTY 2000 Ohm</p>

10.3 Ingresso analogico normalizzato Modelli: ATR110-2xAD, ATR120-2xAD	
	<p>Per segnali normalizzati in tensione 0...10V</p> <p>Rispettare le polarità</p>
	<p>Per segnali normalizzati in corrente 0 ÷ 20mA oppure 4 ÷ 20mA con sensori a tre fili.</p> <p>Rispettare le polarità A= alimentazione sensore B= massa sensore C= uscita sensore</p>

<p>Per segnali normalizzati in corrente $0 \div 20\text{mA}$ oppure $4 \div 20\text{mA}$ con sensori ad alimentazione esterna</p> <p>Rispettare le polarità B= massa sensore C= uscita sensore</p>	<p>Per segnali normalizzati in corrente $4 \div 20\text{mA}$ con sensori a due fili.</p> <p>Rispettare le polarità A= alimentazione sensore C= uscita sensore</p>

10.4 Uscita/e
Modelli: ATR110-xxAD e ATR120-xxAD

	<ul style="list-style-type: none"> • Portata contatti : 8A/250V~ per carichi resistivi (manovre 2×10^5 min a $10^\circ / 250\text{V} \sim$) • Configurabili se N.O. o N.C. per uscita comando e/o allarme
--	--

10.5 Uscita SSR
Modelli: ATR110-x1AD e ATR120-x1AD

	<p>Portata 12V/50mA Uscita comando con configurazione relè stato solido (SSR)</p>
--	--

11 SCHEMA DI COLLEGAMENTO

ATR110 / ATR140 ALIMENTAZIONE DA RETE

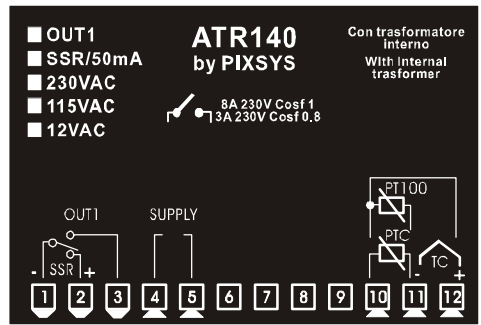
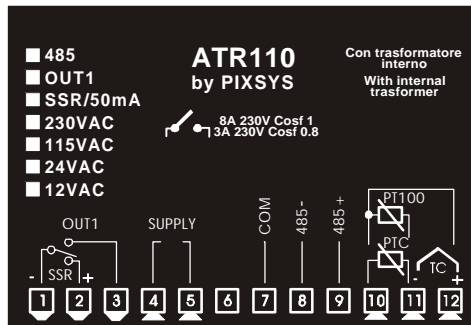

11.1 Alimentazione da rete a 115/230 Vac

Modelli: ATR110-xxB o C e ATR140-xxB o C

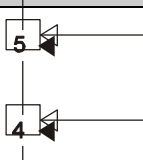

230Vac +/- 10% 50/60Hz
115Vac +/- 10% 50/60Hz

11.2 Ingresso analogico per sonde in temperatura

Modelli: ATR110-1xB o C, ATR140-1xB o C

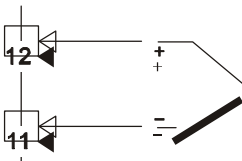

Per termocoppia K, J;
Rispettare le polarità
Per eventuali prolunghe utilizzare cavo compensato adatto alla termocoppia utilizzata.

	<p>Per termoresistenza Pt100 a tre fili, Per il collegamento a tre fili usare cavi della stessa sezione. Per Pt100 a due fili cortocircuitare morsetti 10 e 12. Attenzione. I due fili A e C essendo in parallelo solitamente sono dello stesso colore.</p>
	<p>Per PTC mod. KTY 1000 Ohm mod. KTY 2000 Ohm</p>

11.3 Uscita OUT1
Modelli: ATR110-xxB o C, ATR140-xxB o C

	<p>Portata contatti: 8A/250V~ per carichi resistivi (manovre 2×10^5 min. a $10^\circ / 250V \sim$) ; Configurabile se N.O. o N.C.</p>
--	--

11.4 Uscita SSR
Modelli: ATR110-x1B o C, ATR140-x1B o C

	<p>Portata 12V/30mA Uscita comando con configurazione relè stato solido (SSR)</p>
--	---

11.5 Comunicazione seriale
Modelli: ATR110-1xT

	<p>Comunicazione compatibile RS485 con protocollo MODBUS-RTU 300BaudRate ATTENZIONE!!!! <u>Non usare resistenza terminazione BUS su entrambi i capi.</u> Massimo numero di SLAVE collegabili su singolo BUS = 16</p>
--	--

12 MODI DI INTERVENTO USCITA ALLARME OUT 2 (SOLO ATR120)

12.1 Intervento di banda (setpoint-processo)

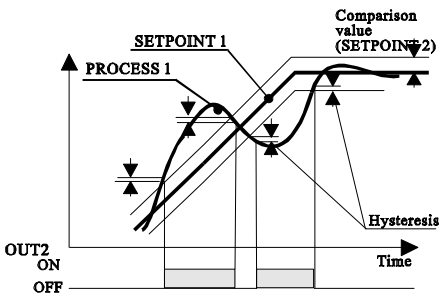

L'allarme può essere :

- Attivo fuori
- Attivo entro

Nell'esempio in figura è attivo fuori.

N.B.: Il valore del setpoint 2 deve essere positivo

12.2 Intervento di deviazione (setpoint-processo)

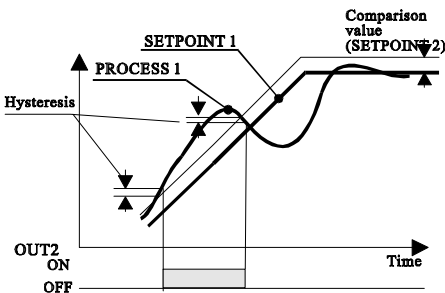

L'allarme può essere :

- di deviazione superiore
- di deviazione inferiore

Nell'esempio in figura è di deviazione superiore.

12.3 Intervento indipendente (processo)

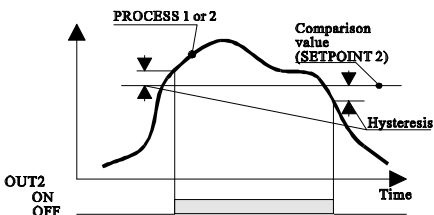

L'allarme può essere :









- Attivo sopra
- Attivo sotto

Nell'esempio in figura è attivo sopra.













13 MODIFICA PARAMETRI DI CONFIGURAZIONE

La configurazione dello strumento è prevista sotto password in quanto di responsabilità del gestore dell' impianto.

Tale password ha la funzione di preservare i parametri di configurazioni da operazioni indesiderate da parte dell'operatore.

	Premere	Effetto	Eseguire
1		Il display dopo circa 5 secondi visualizza  con la prima cifra da sinistra lampeggiante.  Nel caso del ATR140	
2		Incrementare la prima cifra al valore "1".	Premere SET1 per passare alla cifra successiva ed inserire la password di configurazione " <u>123</u> " o " <u>1234</u> " per ATR140
3		Il display visualizza il primo parametro della tabella di configurazione  .	
4		Con i tasti freccia è possibile scorrere in avanti e indietro tutta la tabella di configurazione.	Scegliere il parametro che si desidera variare, premere il tasto  per visualizzarlo e i tasti freccia per le selezioni previste dalla tabella di seguito indicata.

14 ELENCO PARAMETRI DI CONFIGURAZIONE



N	Display	Descrizione parametro	Range di inserimento
1.1	 Su Modelli: ATR110-1xxx ATR120-1xxx ATR110-B/C ATR140	Per ATR110/120-1XX Definisce il tipo di termocoppia o termoresistenza collegata all'ingresso sensore. ATTENZIONE (solo per modelli -1xAD) Per un corretto funzionamento dello strumento, utilizzare sonde isolate da terra. In caso contrario, utilizzare singolo trasformatore isolato per ogni strumento.	 termocoppia K  termocoppia J  PT100  PTC 1000ohm  PTC 2000ohm
1.2	 Su Modelli: ATR110-2xxx ATR120-2xxx	Per ATR110/120-2XX Definisce il tipo di ingresso collegato ai morsetti.	 0...10V  0...20mA  4...20mA
2	 Su Modelli: ATR110 ATR120 ATR110B/C	Seleziona la visualizzazione con il decimo di grado. N.B.: Escluse Termocoppie.	 con decimo  senza decimo

3	H4.1 Su Modelli: ATR110 ATR120 ATR110B/C ATR140	Definisce l'isteresi nel calcolo delle soglie di intervento dell'uscita OUT1. Durante il funzionamento in PI - PID assume la funzione di Banda Morta(zona di inibizione dell'uscita di comando).	-9.9..12.7 °C -9.9..12.7 Unità di misura (per ingressi V/I)
4	Lo.1 Su Modelli: ATR110 ATR120 ATR110B/C ATR140	Definisce il limite inferiore della scala SET1. Il SETPOINT 1 non può essere impostato al di sotto di questo valore. Per ingressi V/I definisce il limite inferiore della scala di funzionamento.	-50..975°C -50..975 Unità di misura (per ingressi V/I)
5	H.1 Su Modelli: ATR110 ATR120 ATR110B/C ATR140	Definisce il limite superiore della scala SET1. Il SETPOINT 1 non può essere impostato al di sopra di questo valore. Per ingressi V/I definisce il limite superiore della scala di funzionamento.	-50...975 °C -50..975 Unità di misura (per ingressi V/I)
6	cr 1 Su Modelli: ATR110 ATR120 ATR110B/C ATR140	Definisce il tipo di contatto per l' uscita OUT1	NO Normalmente aperto (Funzione caldo) NC Normalmente chiuso (Funzione freddo)
7	Sr 1 Su Modelli: ATR110 ATR120 ATR110B/C ATR140	Definisce lo stato del contatto per l' uscita OUT1 in caso di anomalia	CO Contatto aperto CC Contatto chiuso

8	Ld1 Su Modelli: ATR110 ATR120 ATR110B/C ATR140	Definisce lo stato del led OUT1 in corrispondenza al relativo contatto	CO Acceso a contatto aperto CC Acceso a contatto chiuso
9	OUT2 Su Modelli: ATR120	Intervento dell' uscita OUT2	AA Indipendente Ab Banda AdS Deviazione superiore AdI Deviazione inferiore
10	H42 Su Modelli: ATR120	Definisce l' isteresi nel calcolo delle soglie di intervento per l' uscita OUT2	-9.9...12.7 °C -9.9...12.7 Unità di misura (per ingressi V/I)
11	Lo2 Su Modelli: ATR120	Definisce il limite inferiore per la scala SET 2. Il SETPOINT 2 non può essere impostato sotto questo valore.	-50...975 °C -50... 975 Unità di misura (per ingressi V/I)
12	Hi2 Su Modelli: ATR120	Definisce il limite superiore della scala SET2. Il SETPOINT 2 non può essere impostato al di sopra di questo valore.	-50....975°C -50... 975 Unità di misura (per ingressi V/I)
13	CR2 Su Modelli: ATR120	Definisce il tipo di contatto per l'uscita OUT2	NO Normalmente aperto NC Normalmente chiuso

14	Sr2 Su Modelli: ATR120	Definisce lo stato del contatto di OUT2 in caso di anomalie di funzionamento	CO Contatto aperto CC Contatto chiuso
15	Ld2 Su Modelli: ATR120	Definisce lo stato del led OUT2 in corrispondenza al relativo contatto	CO Acceso a contatto aperto CC Acceso a contatto chiuso
16	F.L Su Modelli: ATR110 ATR120 ATR110B/C ATR140	Definisce il valore del filtro software sulla lettura per stabilizzare il DIGIT(cifra) meno significativo in caso di oscillazioni	1..5 DIGIT
17	PS2 Su Modelli: ATR120	Definisce la possibilità per l'operatore di modificare il SETPOINT 2	FrE Accesso abilitato Pro Accesso disabilitato
18	cAO Su Modelli: ATR110 ATR120 ATR110B/C ATR140	Definisce la correzione offset sulla visualizzazione dell'ingresso sensore. (Numero che si somma/sottrae al valore di processo visualizzato; normalmente usato per corregge il valore di temperatura ambiente)	-9.9 ... 12.7 °C -9.9...12.7 Unità di misura (per ingressi V/I)
19	cAC Su Modelli: ATR110 ATR120 ATR110B/C ATR140	Definisce la calibrazione del guadagno sull'ingresso sensore (valore che moltiplica il numero visualizzato per eseguire calibrazioni sul punto di lavoro del processo)	-9.9...12.7%

20	Pd Su Modelli: ATR110 ATR120 ATR110B/C ATR140	Se diverso da 0 Definisce la banda proporzionale nel funzionamento P.I. o P.I.D. Inerzia del processo in unità (in °C se temperatura)	0..255 °C 0(Zero) esclude l'azione proporzionale e abilita il funzionamento ON/OFF.
21	ti Su Modelli: ATR110 ATR120 ATR110B/C ATR140	Definisce il tempo integrale dell'azione P.I. Inerzia del processo in secondi	0..950 sec.. 0(Zero) esclude l'azione integrale 0..60,0 min su ATR110B/C, ATR140
22	tP Su Modelli: ATR110 ATR120 ATR110B/C ATR140	Definisce la durata del ciclo per l'uscita a tempo proporzionale (per contattori normalmente superiore a 10, per SSR normalmente a 1)	1...120 sec.
23	td Su Modelli: ATR110B/C ATR140	Definisce il tempo derivativo dell'azione P.I.D. Normalmente ¼ del tempo integrale	0..25.5 minuti 0(Zero) esclude l'azione derivativa

24	tun Su Modelli: ATR110B/C ATR140	Selezione tipo Autotuning (calcolo automatico di parametri PID ottimali per il funzionamento dell'impianto) Si attiva per un valore di processo inferiore di almeno 35% al valore di setpoint impostato.	Aut calcolo automatico dei parametri P.I.D. ad ogni accensione dello strumento o modifica del setpoint; MAN funzione attivata manualmente premendo i   tasti ; d 15 funzione disabilitata
25	ind Su Modelli: ATR110-BT ATR110-CT	Permette di impostare l'indirizzo dello strumento per la comunicazione seriale.	0..255 Default : 1
26	dEL Su Modelli: ATR110-BT ATR110-CT	Introduce un ritardo alla risposta di "X" millisecondi dopo aver ricevuto un comando MODBUS	0.. 255 millisecondi Default: 100 mS

15 TUNING

L'operazione di tuning consente di calcolare i parametri PID al fine di ottenere una buona regolazione. Ciò significa:

Controllo stabile della temperatura di setpoint senza fluttuazioni;

Risposta veloce alle deviazioni dal setpoint causate da disturbi esterni, riportando così rapidamente la temperatura al valore di setpoint;

L'operazione di tuning prevede il calcolo ed il settaggio dei seguenti parametri:

Banda proporzionale (inerzia del sistema in °C con temperature).

Tempo integrale (il tempo impiegato dal regolatore per rimuovere segnalazioni di errore fisse, corrisponde all'inerzia del sistema in tempo).

Tempo derivativo (determina l'intensità della reazione del regolatore alla variazione del valore misurato, normalmente $\frac{1}{4}$ del tempo integrale).

16 TECNICA DI TUNING MANUALE PER ATR110/120 VERS. AD

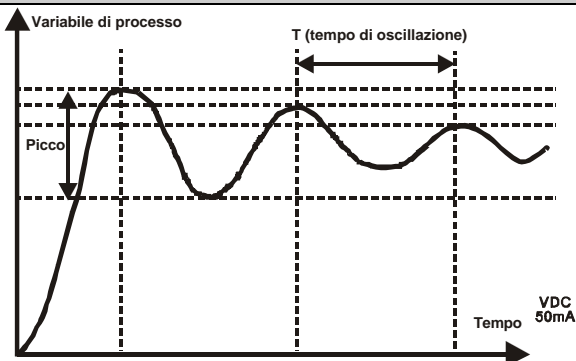

Se l'autotuning, nei regolatori che lo prevedono, dovesse dare risultati insoddisfacenti, si può procedere manualmente all'operazione di tuning: Impostare il setpoint al valore desiderato.

Impostare la banda proporzionale a "0", per avere una regolazione di tipo ON/OFF.

Osservare l'andamento della variabile di processo, si verificherà un comportamento simile a quello raffigurato:

Memorizzare il picco della prima oscillazione.

Memorizzare il tempo "T" tra la seconda e la terza oscillazione.

Impostare i parametri come segue:

Banda proporzionale = Picco x 1,2

Tempo integrale = T x 2

Tempo derivativo = Tempo integrale / 4

Per valutare l'ottimizzazione dei parametri, cambiare il valore di setpoint e controllare il comportamento transitorio. Se persiste l'oscillazione aumentare la banda proporzionale, se invece la risposta è troppo lenta diminuirne il valore.

17 LANCIO DEL TUNING (SOLO ATR110 E ATR140 B / C)

Al lancio della procedura di Tuning viene calcolato un valore teorico di setpoint (TUNING SET) posizionato a metà tra il valore del processo al momento del lancio della procedura di tuning e il valore di setpoint impostato dall'utente. **Al fine di evitare overshoot, la procedura di tuning inizia solo se il valore del processo è inferiore al setpoint almeno del 30% .**

Al raggiungimento del setpoint teorico l'uscita viene spenta e inizia il calcolo del valore del picco e del tempo di oscillazione.

18 TECNICA DI TUNING AUTOMATICO

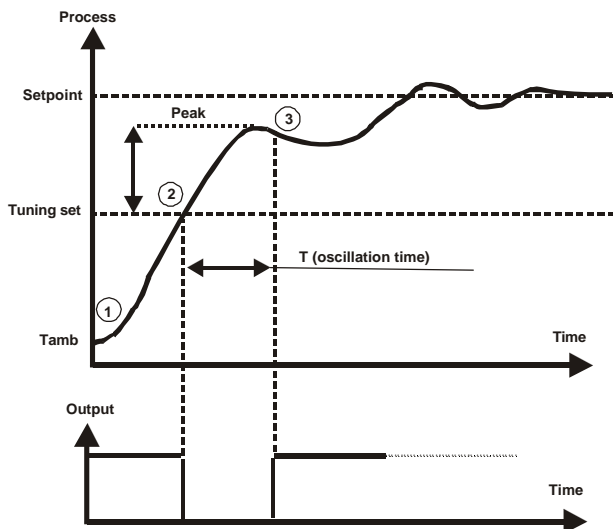

Quando la temperatura inizia a scendere vengono calcolati i valori dei parametri usando le seguenti formule:

Banda proporzionale (gradi) = Picco * 1.3

Tempo integrale (min) = tempo di oscillazione

Tempo derivativo (min) = Tempo integrale / 4

Calcolati i valori, il display smette di lampeggiare e i parametri vengono memorizzati:

nella memoria non volatile (EEPROM) in caso di Tuning lanciato manualmente

nella memoria RAM nel caso di Tuning automatico (in quanto i valori cambiano ad ogni accensione o modifica del Set)

Per valutare l'ottimizzazione dei parametri, cambiare il valore di setpoint e controllare il comportamento transitorio. Se persiste l'oscillazione aumentare la banda proporzionale, se invece la risposta è troppo lenta diminuirne il valore.

Per terminare la procedura prima che sia stata completata, premere il tasto  .

19 COMUNICAZIONE SERIALE (SOLO SU MOD. ATR110-12BT -12CT)

L'ATR110 con RS485 è in grado di ricevere e trasmettere dati via seriale con l'utilizzo di codici del protocollo MODBUS RTU. Questo sistema permette di facilitare il controllo di più unità ATR110 collegandole ad un unico sistema di supervisione. La linea RS485 deve essere priva delle resistenze di terminazione tipiche (causa mal funzionamento strumenti). Nell'ATR110 la velocità di comunicazione è di 300 baud, 8, 1, N, ciò significa che può essere letta o scritta una word al secondo.

Ogni strumento risponderà ad una stringa d'interrogazione solo se questa contiene l'indirizzo uguale a quello contenuto nel parametro IND, gli indirizzi permessi vanno dal 1 al 254 mentre l'indirizzo 255 viene usato per comunicare con tutte le macchine collegate. (Non devono esserci più ATR110 con lo stesso indirizzo)

L'ATR110 è in grado di riconoscere i seguenti codici di operazione MODBUS:

03 : lettura di word (limitato alla lettura di 1 sola word per volta).

06 : scrittura di una word.

L'ATR110-B può introdurre un ritardo in millisecondi alla risposta da interrogazione, che deve essere impostato sul parametro DEL.

Ad ogni scrittura di word lo strumento salva il valore sulla memoria EEPROM interna tale memoria può essere scritta per un massimo di 100.000 volte (nessun limite sulle letture).

NB: Modifiche apportate a Word diverse da quelle riportate nella tabella seguente possono causare mal funzionamenti dello strumento.

Word Modbus	Parametro	Valore di inserimento	Azione
67	Taratura	0 .. 7 Vedi tabella codici	R/W
68	Processo		R
70	SEN	0=TCK .. 3=PTC (KTY)	R/W
71	DP	4=ON 5=OFF	R/W
72	HY1	-99 ... +127	R/W
86	LO1	-50 ... 999	R/W
88	HI1	-50 ... 999	R/W
73	CR1	6=no 7=nc	R/W
74	SR1	8=co 9=cc	R/W
75	LD1	8=co 9=cc	R/W
76	FIL	0 ... 20	R/W
77	CAO	-99 ... +127	R/W
78	CAG	-99 ... +127	R/W

79	PD	0 .. 255	R/W
80	TI	(0 ... 255) 255 per 60.0 minuti	R/W
81	TD	(0 ... 255) 255 per 25.5 minuti	R/W
82	TP	0 ... 100	R/W
83	TUN	10=aut 11=man 12=dis	R/W
84	IND	0 ... 255	R/W
85	DEL	0 ... 255	R/W
90	SETPOINT	-50 .. 9999	R/W
175	% uscita di comando regolazione PID	0 ... 32700 per uscita da 0 a 100%	R
182	T. ambiente di Taratura	-1000 + 1000 per -100.0 a 100.0 °C di temperatura ambiente da FISSARE con codice di taratura 7	W

19.1 Taratura seriale (solo su modelli ATR110-12BT-12CT)

Per la taratura via seriale viene usata la W67 dove possono essere inseriti uno per volta i seguenti codici (il loro ritorno a zero è la conferma dell'avvenuta esecuzione dell'operazione):

Codice 1 : Taratura 0°C per ingresso PT100;

Codice 2 : Taratura 400°C per ingresso PT100;

Codice 3 : Taratura 820Ohm (0°C) per ingresso PTC1000;

Codice 4 : Taratura 1680Ohm (1000°C) per ingresso PTC1000;

Codice 5 : Taratura 0mV per ingressi termocoppie;

Codice 6 : Taratura 40mV per ingressi termocoppie;

Codice 7 : Taratura temperatura giunto freddo (Fissa come temperatura ambiente il dato scritto sulla word 182 in 1/10 °C).

Per la taratura del giunto freddo inserire, prima di iniziare il ciclo di taratura, il valore della temperatura ambiente nella W182.

20 SECTION FOR THE USER

21 DISPLAYS AND KEYS

It usually visualizes the process (es. temperature sensor), but it can show also the setpoint value, or the value of the entering data.

In programming mode it

Increases

Decreases

the value of the parameter (with autorepeat).

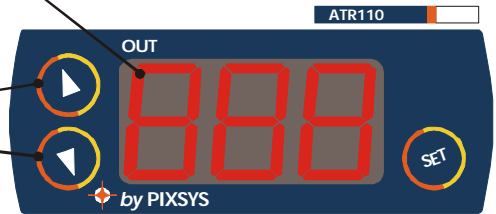

It visualizes the value of setpoint no. 2 (temperature value entered for second treshold). If pushed together with one of the arrow-keys, it allows to change that value..

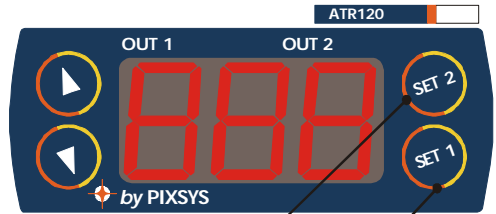



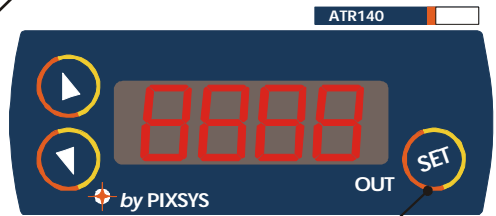





It visualizes the value of setpoint no. 1 (temperature value entered for first treshold). If pushed together with one of the arrow-keys, it allows to change that value..



22 CHANGE OF SETPOINT VALUE

To modify the setpoint value, press SET key and the chosen arrow-key at the same time. After a few seconds, numeric value on display will scroll quickly until the chosen value is reached and the keys are released.

	Press	Display	Do
1	  0	The display visualizes the set-point value (1 or 2)	Keep pushing the key to change the setpoint value
2	  +  	The setpoint value increases or decreases according to the pushed key	Push the key  or  together with one of the arrow keys to increase or decrease the set-point value. When the keys are released, the new value is automatically stored

23 LIST OF ANOMALY SIGNS

If the plant does not work properly, the controller stops the running cycle and visualizes the anomaly.

For example the controller will notice the failure of a thermocouple displaying **E-5** (flashing).

For further anomaly signs look at the list below.

Error	Cause	Do
E-1	Error EEPROM / Writing	
E-4	Parameter error	Check or reconfigure the parameters
E-5	Thermocouple/thermoresistance open or short-circuited - temperature out of range	Check the connections with the sensors and their integrity
E-6	ADC conversion out of range	Check the connection with the sensors and their integrity.
E-7	Cold link out of range	Room temperature probably out of limit.

24 SECTION FOR THE INSTALLER

25 INTRODUCTION

Thanks for choosing a Pixsys controller.

This line of controllers size 32x74 is highly flexible through selectable sensor input. The range includes one model for temperature sensors and one model with linear input. A model with 4 digits display is also available for high temperature applications and visualization of thermocouples type K up to 1350°C.

Control action is ON/OFF with hysteresis and PI for version 12/24Volt, while PID- control with Autotuning function is available on models with internal transformer (115/230Volt).

The tables below allow to select easily the required model.

26 ORDERING CODE

26.1 Ordering code Model ATR110

Display 3 digits, low voltage power supply

Single setpoint, PI-control

ATR110-	<input type="checkbox"/>	<input type="checkbox"/>	<input type="checkbox"/>	
Inputs	1			Thermoresistance PT100, PTC1000, PTC2000 Thermocouple K , J (ISOLATED sensors only) 0/4...20mA 0...1/10Volt
	2			
Outputs	0			Only visualization
	1			1 logic 12....24V/50mA
	2			1 Relay 8A
Power supply			AD	12...24V AC/DC ±10% 50/60Hz

26.2 Ordering code Model ATR120
Display 3 digits, low voltage power supply
Double setpoint, PI-control

ATR120-	<input type="checkbox"/>	<input type="checkbox"/>	<input type="checkbox"/>	
Inputs	1			Thermoresistance PT100, PTC1000, PTC2000 Thermocouple K , J (ISOLATED sensors only) 0/4...20mA 0...1/10Volt
	2			
Outputs	1			1 logic 12....24V/50mA + 1 Relay 8A 2 Relay 8A
	2			
Power supply			AD	12...24V AC/DC $\pm 10\%$ 50/60Hz

26.3 Ordering code Model ATR110
Display 3 digits, power supply 115/230
Single setpoint, PID-control, Autotuning, optional serial RS485.

ATR110-1				Inputs Thermocouple K , J , PT100
Outputs	1			1 SSR (12V 30mA)
	2			1 Relay 8A
Power supply		B		230 Vac $\pm 10\%$ 50/60 Hz
		C		115 Vac $\pm 10\%$ 50/60 Hz
Serial communication			T	RS485 (ModbusRTU,300Baud)

26.4 Ordering code Model ATR140
Display 4 digits, power supply 115/230V
Single setpoint, PID-control,
Autotuning to visualize reading of thermocouple type K up to 1350°C.

ATR140-1				Inputs Thermocouple K , J e PT100
Outputs	1			1 SSR (12V 30mA)
	2			1 Relay 8A
Power supply		B		230 Vac $\pm 10\%$ 50/60 Hz

C	115 Vac \pm 10% 50/60 Hz
---	----------------------------

27 TECHNICAL DATA

27.1 General features

Displays	3 display ATR110 / 4 display ATR140/ (0,56 inches) + 2 led
Operating temperature	0-45°C - humidity 35..95uR%
Sealing	Front Panel IP54 / Box IP30 / Terminal connections IP20
Material	ABS UL94V0 Self-exstinguish
Weight	Approx. 100 gr.

27.2 Hardware data

Analogic inputs	1 AN1	
	Software configurable Thermocouples : K,J Thermoresistances : PT100, KTY 1000/2000 ohm 0/4..20mA (Ri<=50ohm) 0..10V(Ri>=1Mohm)	Tolerance (25°C) 0.5 % ± 1digit for Thermocouples and RTD Cold junction 0.1°C/°C of ambient temperature 0.2% ± 1 digit for V/I
Outputs	1 / 2 Relays : OUT1, OUT2 (onlyATR120)	
	OUT1 : control OUT2 : configurable alarm	8A-250V~contacts (resistive loads)

27.3 Main software data

Regulation algorithym	On/OFF with hysteresis or P.I.. ATR110/120-AD On/OFF with hysteresis or P.I.D. ATR110/140 B -C
Data protection	Configuration password

27.4 Sizes and installation

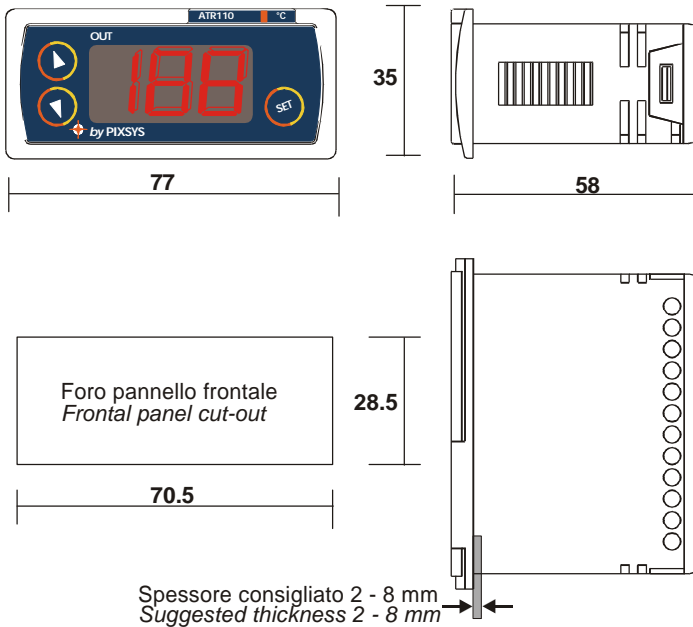

28 ELECTRICAL WIRINGS



Although this controller has been conceived to resist the worst noises in an industrial environment, please notice the following safety guidelines:

- Separate control lines from the power wires
- Avoid the proximity of remote control switches, electromagnetic meters, powerful engines.
- Avoid the proximity of power groups, especially those with phase control

29 WIRING PLAN

ATR110 / ATR120 - LOW VOLTAGE 12..24

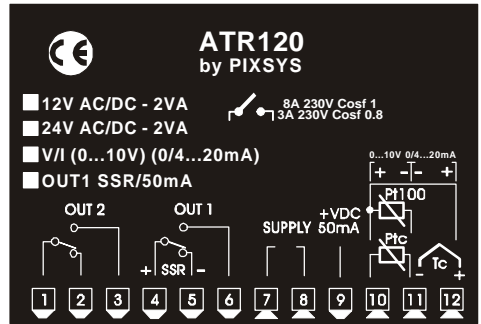
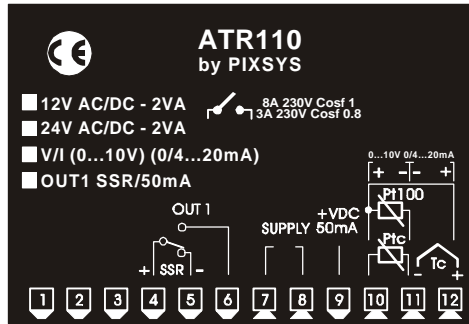

29.1 Power supply 12/24 Vac-Vdc

Models: ATR110-xxAD and ATR120-xxAD

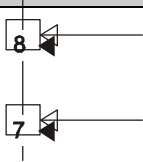

12Vac...24Vac +/- 10% 50Hz/60Hz

29.2 Analogic input no. 1 for temperature sensors

Models: ATR110-1xB o C, ATR140-1xB o C

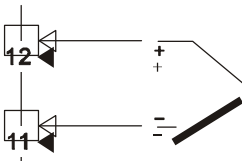

For thermocouples K, J

Respect polarities

For eventual extensions, use the compensating cable suitable for the used thermocouple

ATTENZIONE only for model -1xAD)

To assure optimal working of the device, use ground-isolated sensors.

Otherwise use single isolated transformers for each controller.

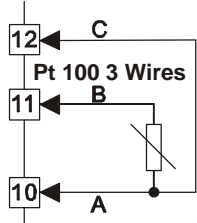
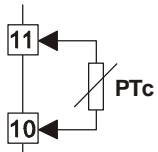
	<p>For thermoresistances Pt100 three-wires</p> <p>For a three-wires PT100 use cables with the same diameter; For two-wires Pt100 short-circuit terminals no. 10 and 12.</p> <p>Wires A and C work in parallel and usually have both the same color.</p>
	<p>For PTC mod. KTY 1000 Ohm mod. KTY 2000 Ohm</p>

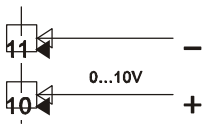
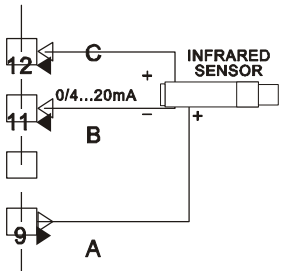
29.3 Linear input Models: ATR110-2xAD, ATR120-2xAD	
	<p>For linear signals 0...10V</p> <p>Respect polarities</p>
	<p>For linear signals 0 ÷ 20mA or 4 ÷ 20mA with three-wires sensors</p> <p>Respect polarities A= sensor power supply B= sensor ground C= sensor output</p>

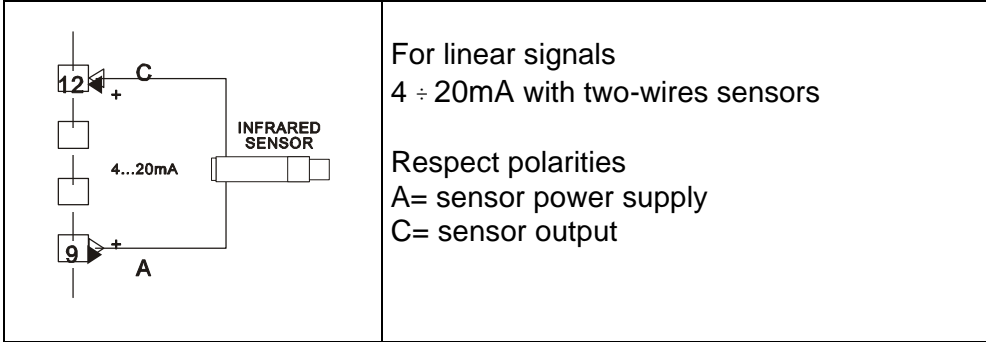
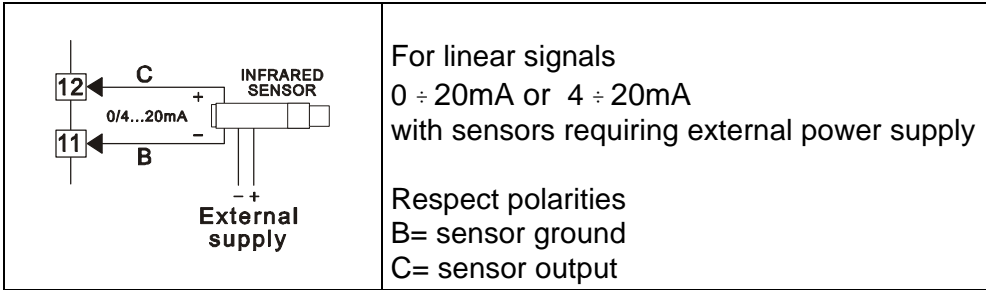

29.4 Relay outputs
Models: ATR110-xxAD and ATR120-xxAD

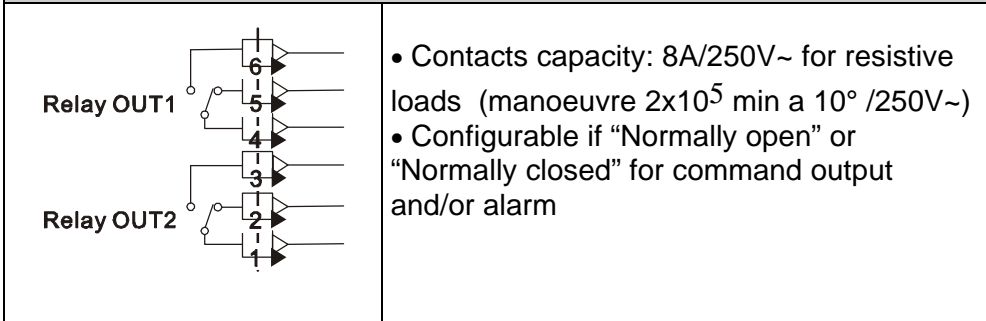

29.5 Out SSR

Models: ATR110-x1AD e ATR120-x1AD

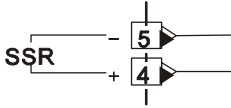

Capacity 12V/50mA
Command output with configuration as SSR

30 WIRING PLAN

ATR110 / ATR140 SUPPLY 115/230V

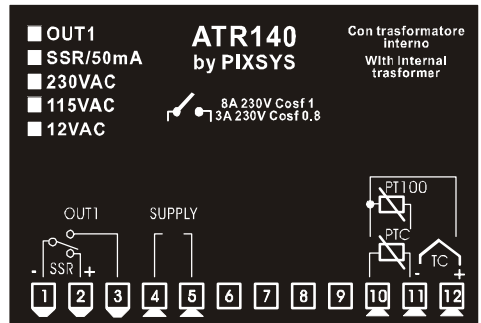
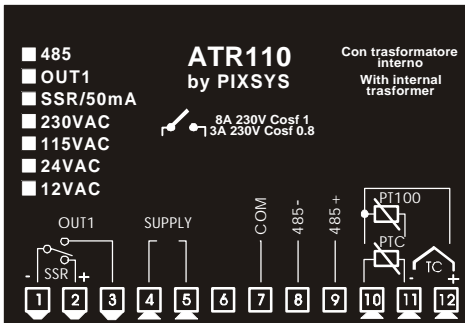

30.1 Power supply 115/230 Vac

Models: ATR110-xxB or C and ATR140-xxB or C

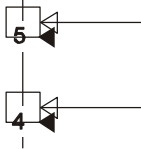

230Vac +/- 10% 50/60Hz
115Vac +/- 10% 50/60Hz

30.2 Analogical input for temperature sensors

Models: ATR110-1xB or C, ATR140-1xB or C

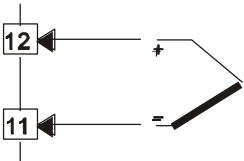
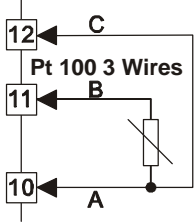
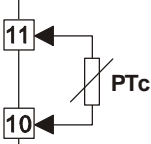
	<p>For thermocouples K, J Respect polarities For eventual extensions, use the compensating cable suitable for the used thermocouple.</p>
	<p>For thermoresistance PT100 For three-wires PT100: use cables with same diameter For two-wires PT100: shortcircuit pins 10 and 12. Attention: Wires A and C work in parallel and usually have both the same color.</p>
	<p>For PTC mod. KTY 1000 Ohm mod. KTY 2000 Ohm</p>

30.3 Output OUT1

Models: ATR110-xxB or C, ATR140-xxB or C

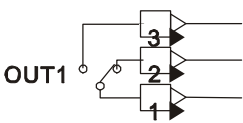

- Contacts capacity: 8A/250V~ for resistive loads (manoeuvre 2×10^5 min. a 10° /250V~);
- Configurable if “Normally open” or “Normally closed”
- For SSR output: current max. 30Ma

30.4 Out SSR

Models: ATR110-x1B or C, ATR140-x1B or C

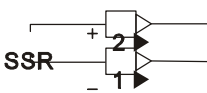

Capacity 12V/50mA
 Command output with configuration as SSR

30.5 Serial communication

Models: ATR110-1Xt

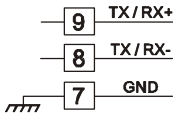

Serial communication RS485 with protocol MODBUS-RTU , 300BaudRate
ATTENTION!

Do not use Bus termination resistance on both heads of the line

Max number of SLAVE units connectable on single BUS = 16

31 ALARM OUTPUT OUT 2 (ONLY ATR120)

31.1 Band alarm (setpoint-process)

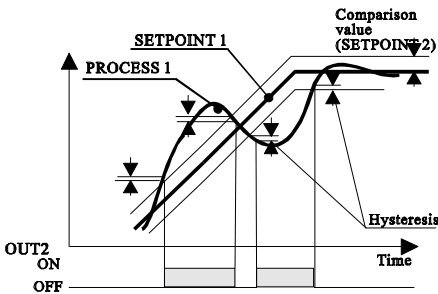

The alarm can be :

- working outside
- working inside

In the example it' s working outside

*The value of sepoint 2 must be positive.

31.2 Deviation alarm (setpoint-process)

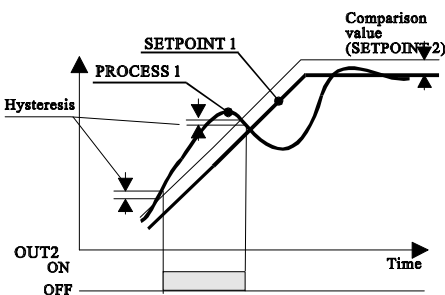

The alarm can be :

- Upper deviation
- Lower deviation

Example: upper deviation..

31.3 Independent alarm (process)

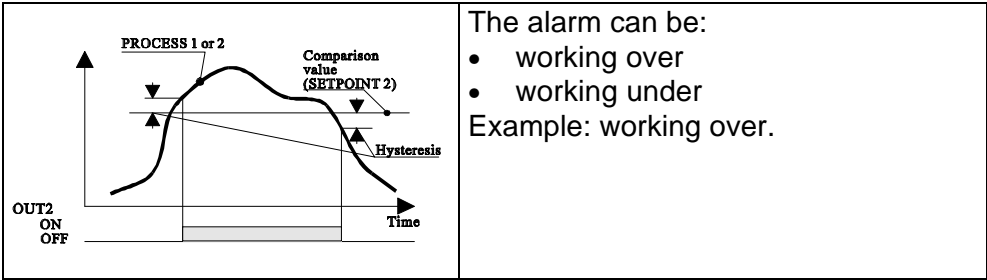









The alarm can be:

- working over
- working under

Example: working over.













32 CHANGE OF CONFIGURATION PARAMETERS









General configuration is protected by password, since it is under responsibility of the installer. The password allows to avoid unauthorised access of the operator to configuration parameters.

	Press	Display	Do
1	 + 	After about 5 seconds, the display visualizes  and the first number on the left flashes.  on ATR140	
2	 	Increase the first digit to "1".	Push SET1 to reach the following number and enter the configuration password " <u>123</u> " Or " <u>1234</u> " for ATR140
3		The display visualizes the first configuration parameter  .	













4		The arrow-keys allow to scroll the configuration table forwards and backwards.	Choose the parameter to modify
---	---	--	--------------------------------



33 CONFIGURATION PARAMETERS



N	Display	Parameter description	Range
1.1	 Models: ATR110-1xxx ATR120-1xxx ATR110-B/C ATR140	For ATR110/120-1XX. Select type of thermocouple or thermoresistance which is connected to the sensor input. ATTENTION ! (only for model -1xAD) To assure optimal working of the device, use ground-isolated sensors. Otherwise use single isolated transformers for each controller.	 thermocouple K  thermocouple J  PT100  KTY 1000 R  KTY 2000 R
1.2	 Models: ATR110-2xxx ATR120-2xxx	For ATR110/120-2XX. Select type of input signal which is connected to the terminals	 0...10V  0...20mA  4...20mA
2	 Models ATR110 ATR120 ATR110B/C	Select the visualization with decimal point. **Thermocouples excluded.	 with decimal  no decimal

3	 Models: ATR110 ATR120 ATR110B/C ATR140	Value of hysteresis in the calculation of the operating thresholds for output OUT1 For PI-control, it assumes the function of dead band (control output is disabled inside this band)	-9.9..12.7 °C -9.9..12.7 Measure unit (for inputs V/I)
4	 Models: ATR110 ATR120 ATR110B/C ATR140	Lower limit of scale SET1. The SETPOINT 1 cannot be set under this value. For V/I inputs it defines the lower limit of the operating scale.	-50..975°C -50..975 Measure unit (for V/I inputs)
5	 Models: ATR110 ATR120 ATR110B/C ATR140	Upper limit of scale SET1. The SETPOINT 1 cannot be set above this value. For V/I inputs it defines the upper limit of the operating scale.	-50...975 °C -50..975 Measure unit (for V/I inputs)
6	 Models: ATR110 ATR120 ATR110B/C ATR140	Type of contact for output OUT1.	 Contact open  Contact closed
7	 Models: ATR110 ATR120 ATR110B/C ATR140	Type of contact for OUT1 in case of anomaly	 Contact open  Contact closed

8	Ld1 Models: ATR110 ATR120 ATR110B/C ATR140	State of led OUT1 according to the state of its contact	CO On with open contact CC On with closed contact
9	ou2 Models: ATR120	Operating of output OUT2	AA Independent Ab Band AdS Upper Ad Lower deviation
10	H42 Models: ATR120	Value of hysteresis in the calculation of the operating tresholds for output OUT2	-9.9...12.7 °C -9.9...12.7 measure unit (for V/I inputs)
11	Lo2 Models: ATR120	Lower limit of scale SET 2. The SETPOINT 2 cannot be set under this value.	-50...975 °C -50... 975 measure unit (for V/I inputs)
12	H12 Models: ATR120	Upper limit of scale SET 2. The SETPOINT 2 cannot be set above this value	-50....975°C -50... 975 measure unit (for V/I inputs)
13	cr2 Models: ATR120	State of contact for output OUT2.	NO Normally open NC Normally closed

14	 Models: ATR120	State of contact for OUT2 in case of anomaly.	 Contact open  Contact closed
15	 Models: ATR120	State of led OUT2 according to the state of its contact	 On with open contact  On with closed contact
16	 Models: ATR110 ATR120 ATR110B/C ATR140	Value of the software filter on the reading of temperature (to stabilize the tenth of degree in case of oscillations)	1..5 tenth of degree
17	 Models: ATR120	Protection of SET2. (Possibility for the operator to change the SETPOINT 2)	 Access enabled  Access denied
18	 Models: ATR110 ATR120 ATR110B/C ATR140	Offset calibration. This value is added the process value visualized on display (usually correcting the ambient temperature)	-9.9 ... 12.7 °C -9.9...12.7 measure unit (for V/I inputs)
19	 Models: ATR110 ATR120 ATR110B/C ATR140	Gain calibration. (The visualized number is multiplied for this % value to calibrate process value)	-9.9...12.7%

20	Pd Models: ATR110 ATR120 ATR110B/C ATR140	Proportional band for P.I. action. Inertia of the process expressed as units (°C if temperature)	0..255 °C 0(Zero) excludes the proportional action and enables the ON/OFF control mode.
21	ti Models: ATR110 ATR120 ATR110B/C ATR140	Integral time for P.I. action. Inertia of the process expressed as seconds	0..950 sec.. 0(Zero) excludes the integral action. 0..60,0 min on ATR110B/C, ATR140
22	tP Models: ATR110 ATR120 ATR110B/C ATR140	Cycle time for time-proportioning output (contactors, SSR...)	1...120 sec.
23	td Models: ATR110B/C ATR140	Derivative time of P.I.D. action (usually ¼ of integral time)	0..25.5 minutes Default : 0.0 min.
24	tun Models: ATR110B/C ATR140	Select type of Autotuning (automatical rating of PID parameters for optimal working of the plant). Function is active only if process value is at least 35% lower than setpoint value.	Aut automatical rating of parameters at each starting of the controller and after changing of setpoint MAN the function is started manually pressing   ; DIS function is disabled

25	 Models: ATR110-BT ATR110-CT	Set the address of the controller for serial communication	0..255 Default : 1
26	 Models: ATR110-BT ATR110-CT	Delay the answer after receiving a Modbus instruction	0.. 255 milliseconds Default: 0 mS

34 TUNING

Tuning operation allows to combine the characteristics of the controller with those of the process being controlled in order to assure good control

- Stable, “straight-line” control of the temperature at setpoint without fluctuations;
- no overshoot or undershoot of the temperature around setpoint;
- quick response to deviations from the setpoint caused by external noises, thereby restoring the temperature rapidly to the setpoint value.

Tuning involves calculating and setting the value of the following parameters:

- Proportional band (the bandwidth in display units over which the power output is proportioned between minimum and maximum);
- Integral time (determines the time taken by the controller to remove steady-state error signals);
- Derivative time (determines how strongly the controller will react to the rate-of-change of the measured value);

35 MANUAL TUNING FOR ATR110/120 VERSION XX-AD

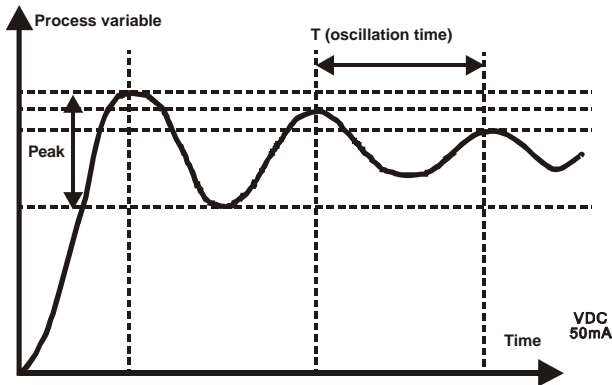

Should the Autotuning fail (on controllers provided with this function), manual Tuning is also possible. Follow the steps below:
Enter setpoint value as required.

Set proportional band to "0" to enable ON/OFF control

Process variable should behave as described by the graph below :

Notice the peak of first oscillation

Notice the time "T" between second and third oscillation

Set parameters as follows:

- Proportional band= Peak x 1,2
- Integral time = T x 2
- Derivative time = Integral time / 4

To evaluate the optimization of parameters, modify setpoint value and observe the transient operation. Should the oscillation still persist, proportional band can be increased. If the response is too slow, decrease the value of proportional band.

36 TUNING START (ONLY ATR110 AND ATR140 B / C)

When the tuning action starts, a theoretical setpoint value (TUNING SET) is rated as the average between the process value at starting of tuning and the setpoint value which has been entered by the operator.

To avoid overshooting, tuning starts only if process value is at least 30% lower than setpoint value.

37 AUTOMATICAL TUNING

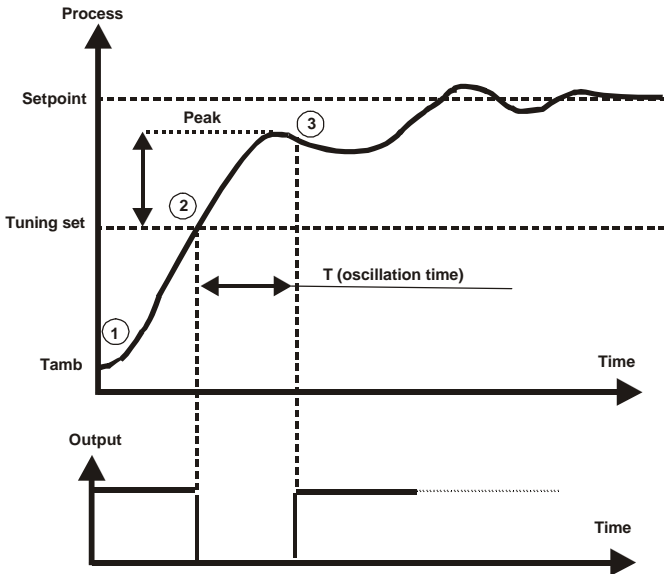

When the ideal setpoint is reached, the output is switched off and the controller starts to rate peak value and oscillation time. When the temperature starts to decrease, parameters are rated according to the following formulae:

- Proportional band (degrees) = Peak * 1.3
- Integral time (min) = oscillation time
- Derivative time (min) = Integral time / 4

When the setting of parameters is complete, the display stops flashing and the parameters are stored :

- a) on EEPROM in case of manual Tuning
- b) on RAM memory in case of automatic Tuning (since the values change at each starting of the controller or changing set value)

To evaluate the optimization of parameters, change the setpoint value and check the transient operation. Should the oscillation persist, increase the proportional band. If the response is too slow, decrease the value of proportional band.

To quit the function before that it is completed, press .

38 SERIAL COMMUNICATION (ONLY ON ATR110-12BT -12CT)

Serial communication and MODBUS protocol enable the controller to receive and exchange data, allowing the connection of more units to a single centralized SCADA.

Transmission format is 300 baud,8,1,N, which means that one single word can be read or written every second.

Each controller will answer an enquiry string only if it contains the same address which is written on parameter IND. The range of admitted addresses is 1 – 254. Address 255 is used to communicate with all the connected units. Single units ATR110 cannot have the same address.

ATR110 does recognize the following MODBUS operating codes:

03 : read one word at one time

06 : write one word at one time

It is possible to delay the answer to polling. This delay (expressed as millisecond) must be entered on parameter DEL.

At each writing, the controller stores the value on EEPROM. This memory can be written max. 100.000 times (readings are unlimited).

NB: Any operation on words which are not listed in the table below may cause anomalies or malfunction.

Word Modbus	Parameter	Range	Action
67	Calibration	0 .. 7 See codes table	R/W
68	Process		R
70	SEN	0=TCK .. 3=KTY	R/W
71	DP	4=ON 5=OFF	R/W
72	HY1	-99 ... +127	R/W
86	LO1	-50 ... 999	R/W
88	HI1	-50 ... 999	R/W
73	CR1	6=no 7=nc	R/W
74	SR1	8=co 9=cc	R/W
75	LD1	8=co 9=cc	R/W
76	FIL	0 ... 20	R/W
77	CAO	-99 ...+127	R/W
78	CAG	-99 ...+127	R/W
79	PD	0 .. 255	R/W

80	TI	(0 ... 255) 255 per 60.0 minutes	R/W
81	TD	(0 ... 255) 255 per 25.5 minutes	R/W
82	TP	0 ... 100	R/W
83	TUN	10=aut 11=man 12=dis	R/W
84	IND	0 ... 255	R/W
85	DEL	0 ... 255	R/W
90	SETPPOINT	-50 .. 9999	R/W
175	% control Output for PID control	0 ... 32700 for OUT from 0 to 100%	R
182	ambient temperature	-1000 + 1000 per -100.0 at 100.0 °C ambient temperature to FIX by calibration code 7	W

38.1 Calibration via serial communication (only on models ATR110-12BT-12CT)

For calibration via serial communication use word W67. The following codes can be entered one at a time

(Reset to zero confirms that operation has been completed):

Code 1 : calibration 0°C for input PT100;

Code 2 : calibration 400°C for input PT100;

Code 3 : calibration 820Ohm (0°C) for input KTY1000;

Code 4 : calibration 1680Ohm (1000°C) for input KTY1000;

Code 5 : calibration 0mV for input TC

Code 6 : calibration 40Mv for input TC

Code 7 : calibration temperature Cold junction (Data are stored on Eeprom).

**For calibration of cold junction, enter value of ambient temperature on W182 before starting the calibration cycle

2300.10.016-RevB 260303

2300. 10. 016- B

TRAFAG ITALIA S.r.l.
c/o Tecnocity Altomilanese
Via Cremona 1
20025 Legnano (MI)

Tel: 0331 592 397
Fax: 0331 599 815
www.trafagititalia.com
info@trafagititalia.com

Cap. Soc. 41600,00 EURO i.v., CCIAA 11819540151 R.E.A. 1502506, P.IVA 11819540151